

Lakeside Preserve Community Development District

3501 Quadrangle Boulevard, Suite 270, Orlando, FL 32817; 407-723-5900
www.lakesidepreserveccd.org

The following is the proposed agenda for the Board of Supervisors meeting for the Lakeside Preserve Community Development District, scheduled to be held **Wednesday, May 31, 2023 at 11:30 a.m. at the Heritage Baptist Church, 4202 Pipkin Creek Rd, Lakeland, FL 33811.** Questions or comments on the Board Meeting or proposed agenda may be addressed to Jane Gaarlandt at gaarlandtj@pfm.com or (407) 723-5900.

To attend the meeting, please use the below conference call information:

Phone: **1-844-621-3956**
Access Code: **790 393 986 #**

PROPOSED BOARD OF SUPERVISORS' MEETING AGENDA

Administrative Matters

- Roll Call to Confirm Quorum
- Public Comment Period *[for any members of the public desiring to speak on any proposition before the Board]*
- 1. **Consideration of Minutes of the January 18, 2023, Board of Supervisors Meeting**
- 2. **Review of Letter from Supervisor of Elections Regarding Qualified Electors**

Business Matters

3. **Consideration of Resolution 2023-01, Approving a Proposed Budget for Fiscal Year 2023-2024 and Setting a Public Hearing Date Thereon *[suggested date: August 16, 2023]***
4. **Consideration of District Engineer Proposal for Facilities Report**
5. **Consideration of Proposals for Chain Link Fence**
 - **Jim Williams Fence Company, Inc.**
 - **Randolph Outdoor, LLC Fence Division**
6. **Consideration of Proposal for Pond Bank Low Spot Remediation**
7. **Consideration of Pond Fountain Option(s)**
8. **Consideration of Payment Authorization Nos. 159, 163, 165 and 167**
9. **Ratification of Payment Authorization Nos. 160 – 162, 164 and 166**
10. **Review of Monthly Financials**

Other Business

Staff Reports

- District Counsel
- District Engineer
- District Manager
 - Field Service Report

Supervisor Requests and Audience Comments

Adjournment



**LAKESIDE PRESERVE
COMMUNITY DEVELOPMENT DISTRICT**

Minutes of the January 18, 2023
Board of Supervisors Meeting

MINUTES OF MEETING

**LAKESIDE PRESERVE COMMUNITY DEVELOPMENT DISTRICT
BOARD OF SUPERVISORS' MEETING**

Wednesday January 18, 2022, at 11:30 a.m.

**Offices of Highland Homes,
3020 S. Florida Avenue, Suite 101,
Lakeland, Florida 33803**

Board Members present at roll call:

Lee Saunders	Chairperson
Brian Walsh	Assistant Secretary
Dan Lewis	Assistant Secretary
Jeff Shenenfield	Assistant Secretary

Also Present:

Jane Gaarlandt	PFM Group Consulting LLC	
Verona Griffith	PFM Group Consulting LLC	(via phone)
Don Hasenbank	PFM Group Consulting LLC	(via phone)
Lauren Gentry	KE Law Group, PLLC	(via phone)
Martha Ledford	TRIAD Management	(via phone)
Madison McAdams	TRIAD Management	(via phone)
Darrel Rusnell	Public	

FIRST ORDER OF BUSINESS

Roll Call to Confirm Quorum

Ms. Gaarlandt called the meeting to order at 11:33 a.m. and roll call was taken.

SECOND ORDER OF BUSINESS

Public Comment Period

There were no public comments.

THIRD ORDER OF BUSINESS

**Consideration of Minutes of the
October 19 2022, Auditor Selection
Committee and Board of Supervisors
Meeting**

The Board reviewed the Minutes of the October 19, 2022, Auditor Selection and Board of Supervisors Meetings.

On MOTION by Mr. Walsh, seconded by Mr. Lewis, with all in favor, the Board of Supervisors for the Lakeside Preserve Community Development District approved the Minutes of the October 19, 2022, Auditor Selection Committee and Board of Supervisor's Meetings.

FOURTH ORDER OF BUSINESS

**Review of Districts Engineer's Site
Inspection Report and
Recommendations
a. Consideration of Proposal for
Dirt/Fill**

Ms. Gaarlandt stated that at the last meeting there was discussion regarding some issues with erosion of some of the pond structures. The engineer went out to inspect and the report included in the agenda packet lays out their findings and recommendation. Ms. Gaarlandt also noted that District staff reached out to the current landscaper to provide the extra dirt needed for the low spot. Ms. Ledford stated she has not yet received a proposal, but has also reached out to another vendor and hopes to get a proposal from as well. Discussion ensued about the grading issue. The Board suggested putting in a PVC pipe and collection box.

Ms. Ledford recommended looking into getting a new landscape company after this project due to the current vendor not being responsive. The Board asked to see if the current vendor can give proposals on this current project before seeking another vendor.

FIFTH ORDER OF BUSINESS

**Consideration of Pond Fountain
Option(s)**

Ms. Gaarlandt stated this is for information only based on the Board having expressed in looking at solar-powered fountains based on the issue with the ponds during the hot months with fish kill because of poor oxygenation. The enclosed information shows pricing between \$8,000.00 and \$12,000. The current budget would not cover this expense.

Discussion ensued about the price difference between Solar-powered and electric fountains.

Ms. Gaarlandt noted that if moving forward it would probably be something the Board would have to consider adding to the budget for the upcoming Fiscal Year.

Ms. Ledford stated she would ask the vendor to come out to inspect in order to provide a proposal for a basic entry level electric option.

SIXTH ORDER OF BUSINESS

**Consideration of Payment
Authorization Nos. 153-158**

Ms. Gaarlandt noted that these were all standard District expenses.

On MOTION by Mr. Walsh, seconded by Mr. Shenenfield , with all in favor, the Board of Supervisors for the Lakeside Preserve Community Development District approved payment authorization Nos. 153-158.

SEVENTH ORDER OF BUSINESS

Review of Monthly Financials

Ms. Gaarlandt stated these monthly financials are as of the end of the year and are for information only, no Board actions is required.

EIGHTH ORDER OF BUSINESS

Staff Reports

- **District Counsel**
- **District Engineer**
- **District Manager**

District Counsel –

No report.

District Engineer –

No report.

District Manager –

Ms. Gaarlandt noted that a resident request to change the meeting time was brought up at the last meeting. The Board agreed the current time is ok for right now.

Discussion ensued about when Seats will transition to General Election. Ms. Gaarlandt elaborated on the process.

Ms. Gaarlandt and Ms. Ledford presented the Field Service Report to the Board. Ms. Gaarlandt noted there were several leaning trees after the hurricane. Being that the landscapers took so long to bring back a proposal they said that they would take care of the trees at no cost to the District. Ms. Ledford noted she spoke with the landscapers this morning, and they advised that their team had taken care of those trees.

Ms. Ledford also stated that she noticed some algae growth that she will monitor, and she will be reaching out

to the aquatic vendor so that they can come out and take a look.

NINTH ORDER OF BUSINESS

Supervisor Requests and Audience Comments

Mr. Rusnell mentioned that a lot of people are coming into the community through the open area in the fence behind the Heritage Baptist Church and asked if the gap in the fence could be closed.

Discussion ensued about adding fencing for the open area to match the existing chain link fence.

The Board requested proposals for chain link fencing to close the gap.

TENTH ORDER OF BUSINESS

Adjournment

On MOTION by Mr. Walsh, seconded by Mr. Lewis, with all in favor, the January 18, 2022, Meeting of the Board of Supervisors for the Lakeside Preserve Community Development District was adjourned.

Secretary/Assistant Secretary

Chairman/Vice Chairman

**LAKESIDE PRESERVE
COMMUNITY DEVELOPMENT DISTRICT**

Review of Letter from Supervisor of Elections
Regarding Qualified Electors



April 21, 2023

Jane Gaarlandt – Senior District Manager
Fishkind & Associates – PFM
3501 Quadrangle Blvd. Ste. 270
Orlando, Florida 32817-1450

RE: Lakeside Preserve Community Development District Registered Voters

Dear Ms. Garrlandt,

In response to your request, there are currently **250** registered voters within the Lakeside Preserve Community Development District. This number of registered voters in said District is as of **April 15, 2023**.

Please do not hesitate to contact us if we can be of further assistance.

Sincerely,

Lori Edwards
Supervisor of Elections
Polk County, Florida

P.O. Box 1460, Bartow, FL 33831 • Phone: (863) 534-5888

PolkElections.gov

Para asistencia en Español, por favor de llamar al (863) 534-5888

LAKESIDE PRESERVE COMMUNITY DEVELOPMENT DISTRICT

Consideration of Resolution 2023-01, Approving a
Proposed Budget for Fiscal Year 2023-2024 and
Setting a Public Hearing Date Thereon
[suggested date: August 16, 2023]

RESOLUTION 2023-01

A RESOLUTION OF THE BOARD OF SUPERVISORS OF THE LAKESIDE PRESERVE COMMUNITY DEVELOPMENT DISTRICT APPROVING PROPOSED BUDGETS FOR FISCAL YEAR 2023/2024 AND SETTING A PUBLIC HEARING THEREON PURSUANT TO FLORIDA LAW; ADDRESSING TRANSMITTAL, POSTING AND PUBLICATION REQUIREMENTS; ADDRESSING SEVERABILITY; AND PROVIDING AN EFFECTIVE DATE.

WHEREAS, the District Manager has heretofore prepared and submitted to the Board of Supervisors (“**Board**”) of the Lakeside Preserve Community Development District (“**District**”) prior to June 15, 2023, proposed budgets (“**Proposed Budget**”) for the fiscal year beginning October 1, 2023 and ending September 30, 2024 (“**Fiscal Year 2023/2024**”); and

WHEREAS, the Board has considered the Proposed Budget and desires to set the required public hearing thereon.

NOW, THEREFORE, BE IT RESOLVED BY THE BOARD OF SUPERVISORS OF THE LAKESIDE PRESERVE COMMUNITY DEVELOPMENT DISTRICT:

1. **PROPOSED BUDGET APPROVED.** The Proposed Budget prepared by the District Manager for Fiscal Year 2023/2024 attached hereto as **Exhibit A** is hereby approved as the basis for conducting a public hearing to adopt said Proposed Budget.

2. **SETTING A PUBLIC HEARING.** A public hearing on said approved Proposed Budget is hereby declared and set for the following date, hour and location:

DATE: _____, 2023

HOUR: _____

LOCATION: _____

3. **TRANSMITTAL OF PROPOSED BUDGET TO LOCAL GENERAL PURPOSE GOVERNMENTS.** The District Manager is hereby directed to submit a copy of the Proposed Budget to the City of Lakeland and Polk County at least 60 days prior to the hearing set above.

4. **POSTING OF PROPOSED BUDGET.** In accordance with Section 189.016, *Florida Statutes*, the District’s Secretary is further directed to post the approved Proposed Budget on the District’s website at least two days before the budget hearing date as set forth in Section 2, and shall remain on the website for at least 45 days.

5. **PUBLICATION OF NOTICE.** Notice of this public hearing shall be published in the manner prescribed in Florida law.

6. **SEVERABILITY.** The invalidity or unenforceability of any one or more provisions of this Resolution shall not affect the validity or enforceability of the remaining portions of this Resolution, or any part thereof.

7. **EFFECTIVE DATE.** This Resolution shall take effect immediately upon adoption.

PASSED AND ADOPTED THIS ____ DAY OF _____, 2023.

ATTEST:

**LAKESIDE PRESERVE COMMUNITY
DEVELOPMENT DISTRICT**

Secretary

By: _____
Its: _____

Lakeside Preserve CDD
FY2024 Proposed Budget

	Year To Date			FY 2023 Adopted Budget	FY 2024 Proposed Budget
	Actual to 04/30/2023	Anticipated May - Sept 2023	Anticipated to September 2023		
<u>Revenues</u>					
On-Roll Assessments	\$ 81,903.12	\$ -	\$ 81,903.12	\$ 81,000.00	\$ 91,000.00
Off-Roll Assessments	71,925.00	23,975.00	95,900.00	95,900.00	95,900.00
Net Revenues	\$ 153,828.12	\$ 23,975.00	\$ 177,803.12	\$ 176,900.00	\$ 186,900.00
<u>General & Administrative Expenses</u>					
Supervisor Fees	\$ 600.00	\$ 428.57	\$ 1,028.57	\$ 2,800.00	\$ 2,400.00
D&O Insurance	2,579.60	-	2,579.60	2,875.00	2,875.00
Trustee Services	2,357.03	3,642.97	6,000.00	6,000.00	4,300.00
Management	13,750.02	13,749.98	27,500.00	27,500.00	27,500.00
Field Management	-	208.33	208.33	500.00	1,200.00
Engineering	545.00	389.29	934.29	5,000.00	5,000.00
Dissemination Agent	-	5,000.00	5,000.00	5,000.00	5,000.00
Property Appraiser	5,000.00	-	5,000.00	5,000.00	5,000.00
District Counsel	2,123.97	13,876.03	16,000.00	16,000.00	16,000.00
Assessment Administration	7,500.00	-	7,500.00	7,500.00	7,500.00
Reamortization Schedules	125.00	875.00	1,000.00	1,000.00	1,000.00
Audit	-	5,500.00	5,500.00	5,500.00	4,400.00
Arbitrage Calculation	-	500.00	500.00	500.00	500.00
Travel and Per Diem	122.78	127.22	250.00	250.00	250.00
Telephone	-	41.67	41.67	100.00	100.00
Postage & Shipping	30.86	12.86	43.72	300.00	300.00
Copies	-	20.83	20.83	50.00	50.00
Legal Advertising	1,018.35	727.39	1,745.74	2,000.00	2,000.00
Miscellaneous	-	396.35	396.35	951.25	7,800.00
Meeting Room	-	250.00	250.00	600.00	600.00
Web Site Maintenance	405.00	2,415.00	2,820.00	2,820.00	2,820.00
Dues, Licenses, and Fees	175.00	-	175.00	175.00	175.00
Electric	496.51	354.65	851.16	2,000.00	2,000.00
Aquatic Contract	5,933.76	4,238.40	10,172.16	10,000.00	10,000.00
General Insurance	3,076.80	-	3,076.80	3,478.75	3,750.00
Property & Casualty	1,509.60	-	1,509.60	3,450.00	3,430.00
Irrigation	777.06	555.04	1,332.10	5,000.00	5,000.00
Landscaping Maintenance & Material	29,855.00	21,325.00	51,180.00	57,500.00	59,900.00
Landscape Improvements	-	833.33	833.33	2,000.00	5,000.00
Contingency	-	1,050.00	1,050.00	1,050.00	1,050.00
Total General & Administrative Expenses	\$ 77,981.34	\$ 76,517.92	\$ 154,499.26	\$ 176,900.00	\$ 186,900.00
Total Expenses	\$ 77,981.34	\$ 76,517.92	\$ 154,499.26	\$ 176,900.00	\$ 186,900.00
Income (Loss) from Operations	\$ 75,846.78	\$ (52,542.92)	\$ 23,303.86	\$ -	\$ -
<u>Other Income (Expense)</u>					
Interest Income	\$ 12.79	\$ -	\$ 12.79	\$ -	\$ -
Total Other Income (Expense)	\$ 12.79	\$ -	\$ 12.79	\$ -	\$ -
Net Income (Loss)	\$ 75,859.57	\$ (52,542.92)	\$ 23,316.65	\$ -	\$ -

Lakeside Preserve Community Development District
FY 2024 Proposed Debt Service Budget

	FY 2024 Proposed DS Budget
REVENUES:	
Series 2019	\$ 117,300.01
TOTAL REVENUES	<u>\$ 117,300.01</u>
EXPENDITURES:	
Series 2019 - Interest 11/1/2023	\$ 30,928.13
Series 2019 - Interest 5/1/2024	30,928.13
Series 2019 - Principal 5/1/2024	25,000.00
TOTAL EXPENDITURES	<u>\$ 86,856.26</u>
EXCESS REVENUES (Series 2019 - Interest 11/1/2024)	<u>\$ 30,443.75</u>

Budget Item Description

Revenues:

On-Roll Assessments

The District can levy a Non-Ad Valorem assessment on all the assessable property within the District in order to pay for the operating expenditures during the Fiscal Year. Assessments collected via the tax collector are referred to as “On-Roll Assessments.”

Off-Roll Assessments

The District can levy a Non-Ad Valorem assessment on all the assessable property within the District in order to pay for the operating expenditures during the Fiscal Year. Assessments collected through direct billing are referred to as “Off-Roll Assessments.”

General & Administrative Expenditures:

Supervisor Fees

Chapter 190 of the Florida Statutes allows for a member of the Board of Supervisors to be compensated for meeting attendance and to receive up to \$200.00 per meeting plus payroll taxes. The amount for the Fiscal Year is based upon all supervisors attending the meetings.

Public Officials’ Liability (POL) Insurance

Supervisors’ and Officers’ liability insurance.

Trustee Services

The Trustee submits invoices annually for services rendered on bond series. These fees are for maintaining the District trust accounts.

Management Fees

The District receives Management and Administrative services as part of a Management Agreement with PFM Group Consulting, LLC. These services are further outlined in Exhibit “A” of the Management Agreement.

Engineering Fees

The District’s engineer provides general engineering services to the District. Among these services are attendance at and preparation for monthly board meetings, review of invoices, and all other engineering services as requested by the District throughout the year.

Annual Disclosure

When bonds are issued for the District, the Bond Indenture requires continuing disclosure, which the dissemination agent provides to the trustee and bond holders.

LAKESIDE PRESERVE CDD

District Counsel

The District's legal counsel provides general legal services to the District. Among these services are attendance at and preparation for monthly board meetings, review of operating and maintenance contracts, and all other legal services as requested by the District throughout the year.

Assessment Administration

The District can levy a Non-Ad Valorem assessment on all the assessable property within the District in order to pay for the operating expenditures during the Fiscal Year. It is typically collected via the Tax Collector. The District Manager submits an Assessment Roll to the Tax Collector annually by the deadline set by the Tax Collector or Property Appraiser.

Re-amortization Schedules

When debt is paid on a bond series, a new amortization schedule must be recalculated. This can occur up to four times per year per bond issue.

Audit

Chapter 218 of the Florida Statutes requires a District to conduct an annual financial audit by an Independent Certified Public Accounting firm. Some exceptions apply.

Travel & Per Diem

Travel to and from meetings as related to the District.

Telephone

Telephone and fax machine services.

Postage & Shipping

Mail, overnight deliveries, correspondence, etc.

Copies

Printing and binding Board agenda packages, letterhead, envelopes, and copies.

Legal Advertising

The District will incur expenditures related to legal advertising. The items for which the District will advertise include, but are not limited to monthly meetings, special meetings, and public hearings for the District.

Miscellaneous

Other unplanned expenses incurred throughout the year.

Hurricane Cleanup

Expenses incurred to cleanup any damages caused by a hurricane.

LAKESIDE PRESERVE CDD

Website Maintenance

Website maintenance fee.

Dues, Licenses & Fees

The District is required to pay an annual fee to the Department of Economic Opportunity.

Electric

Utility fees paid

Irrigation

Irrigation meters are located throughout the District and serviced by the local water department.

General Insurance

General liability insurance.

Property & Casualty

Insurance to protect property and cover casualty.

Landscaping Maintenance & Material

Any planting, flowers, annuals, etc., used during the year to maintain green area, etc.

LAKESIDE PRESERVE COMMUNITY DEVELOPMENT DISTRICT

Consideration of District Engineer Proposal
for Facilities Report

April 14, 2023

Ms. Jane Gaarlandt, District Manager
Lakeside Preserve CDD
3501 Quadrangle Blvd, Suite 270
Orlando, FL 32817

Re: **LAKESIDE PRESERVE – FACILITIES REPORT**
Hillsborough County, Florida
LESC # 2170075

Jane:

Landmark Engineering & Surveying Corporation (Landmark) is pleased to present this proposal for engineering services for the Lakeside Preserve CDD.

The scope of services includes the following:

- Prepare a Public Facilities Report for the District

FEE: Lump Sum \$2,500.00

Landmark thanks you for the opportunity to present this proposal and looks forward to your favorable response. You may expedite the approval by emailing the signed *Authorization to Proceed* to my attention.

If you should have any questions or comments, please do not hesitate to contact our office.

Sincerely,
LANDMARK ENGINEERING &
SURVEYING CORPORATION



Todd C. Amaden, P.E., EMBA
President

AUTHORIZATION

The signature below authorizes the work herein described and does so on behalf of the Signatory and on behalf of the *Lakeside Preserve CDD* upon which Landmark's work is to be performed and warrants that he has authority to sign this Agreement on behalf of the Signatory and on behalf of the *Lakeside Preserve CDD*.

Read and approved this _____ day of _____, 2023

By:

SIGNATURE: _____

TITLE: _____

2023 FEE SCHEDULE

<u>SERVICE</u>	<u>RATE/HOUR</u>
Expert Witness	\$ 300.00
Principal	\$ 250.00
Senior Professional Engineer / Surveyor	\$ 175.00
Senior Project Manager	\$ 150.00
Professional Engineer / Surveyor	\$ 135.00
Field Engineer	\$ 135.00
Project Manager	\$ 125.00
Designer	\$ 110.00
CADD / Drafting	\$ 95.00
Field Inspector	\$ 85.00
Technician	\$ 75.00
Administrative	\$ 65.00
Survey Field Crew	\$ 135.00
Copies & Printing	COST
Per Diem/Person	\$ 75.00
Outside Professional Services, Materials, Photographic Reproductions, Agency Fees, etc.	Cost + 15%



**LAKESIDE PRESERVE
COMMUNITY DEVELOPMENT DISTRICT**

Consideration of Proposals for Chain Link Fence

JIM WILLIAMS FENCE COMPANY, INC.

ESTABLISHED 1959

934 East Rose Street, Lakeland, FL 33801

Attn: Madison McAdams

PROPOSAL

For: Lakeside Preserve
 Address: Pipkin Creek Rd
Lakeland 33811

Mobile Phone: 813-469-8491 **Date** 2/13/23
 Home Phone: _____ Work: _____
 Subdivision: Lakeside Preserve Fax: _____

E-mail: _____ Job Address: meet at the front of subdivision
 Survey stakes visible _____ Survey provided Will Send

FENCE SPECIFICATIONS - CHAIN LINK

Install 193' Type chain link Height 5ft Gauge 9 gauge Mesh 2" mesh

Black vinyl coated

Posts Type	Size	Length	Wall Thickness
Line	<u>1 5/8" x 7'</u>		<u>.065 wall</u>
Terminal	<u>2 1/2" x 7'</u>		<u>.065 wall</u>
Gate	<u>N/A</u>		

Black vinyl coated

Posts set 10' o.c. in concrete.
 Top rail 1 3/8" o.d.
 Tension wire not included Gauge _____

Gates	Width	Height	Frame	Type
<u>A</u>	<u>10'</u>	<u>5'</u>	<u>A</u>	<u>_____</u>

Barb up Barb down
 Fence is approx. 0" off of ground.

Fence / Grade Elevations	(See back of contract for examples)
A B C D (circle one)	
_____ Customer Initials	

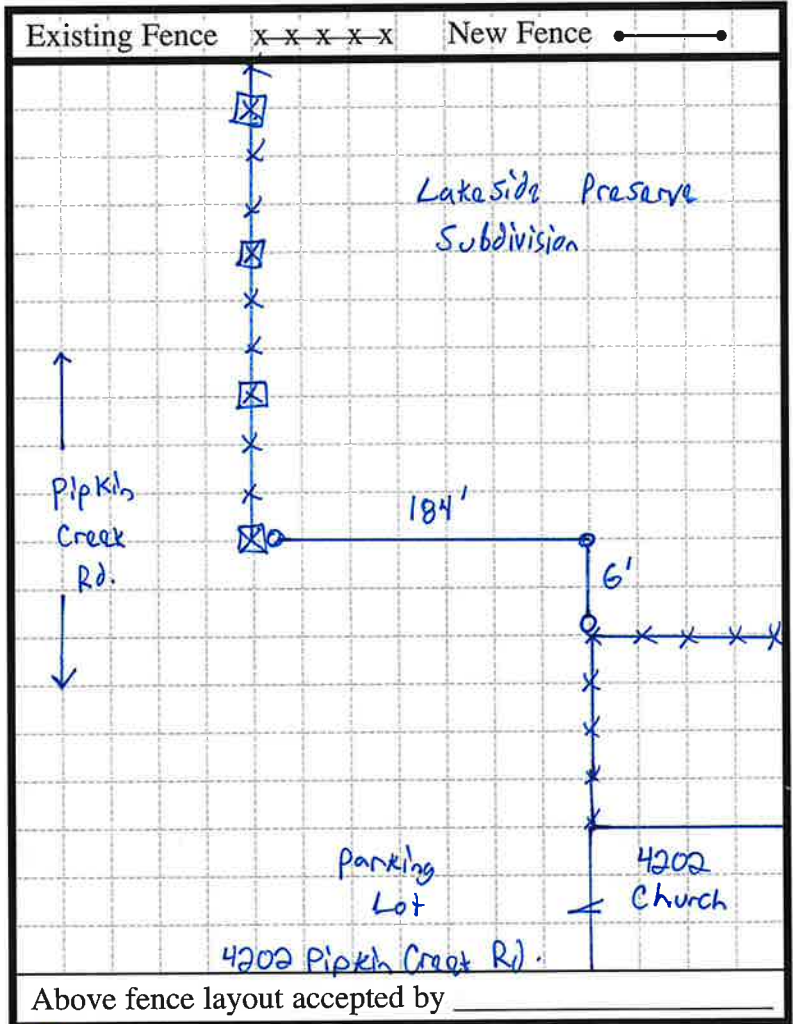

DIRT ASPHALT CONCRETE

OPTIONS: _____

TERMS: 1/2 Deposit Balance On completion.

(* All contracts are plus permit fees, if required. Tax if applicable \$ _____
All fence lines must be cleared + marked by customer (*) Total Contract \$ 3,272.00

Approximate start date _____ Approximate completion date _____

By Wayne Sargent Accepted _____ Date _____

The undersigned agrees to terms on back of contract.

Lakeland 863-688-1194 / Fax 863-683-6402
 Serving Central Florida Since 1959 • Certified Drug-Free Workplace



THIS PROPOSAL MAY BE WITHDRAWN IF NOT ACCEPTED WITHIN 30 DAYS.

ADDITIONAL TERMS: Jim Williams Fence Company, Inc. ("Contractor") is not responsible or liable for any injury or damage resulting from use or misuse including, but not limited to climbing, scaling or under-passage of any fence, gate or other improvement installed by it on the premises of Owner. Location of all work and improvements on the property, location or damage to any underground pipes, cables or wires and compliance with any applicable deed restrictions or protective covenants is the responsibility of Owner.

Unless specifically stated otherwise, this quotation does not include grading, trimming, clearing of vegetation or debris. All fence lines to be cleared by owner unless otherwise specified.

Damage done to any improvements or work performed by Contractor by any Act of God, excessive wind, hazardous materials or chemicals, standing water, flooding or fires are not warranted by Contractor.

This proposal becomes a contract when accepted by Owner. Canceled contracts are subject to a 20% cancellation fee. Unless otherwise stated herein, the sums due hereunder shall be due and payable upon completion of the work. All sums not paid within terms listed are subject to interest charges of 1.5% a month from the completion date of the work. In the event contractor must employ an attorney to collect any sums due hereunder or enforce any of the terms of this contract, Owner agrees to pay any attorney's fee and costs incurred by Contractor.

THIS PROPOSAL MAY BE WITHDRAWN IF NOT ACCEPTED WITHIN 30 DAYS.

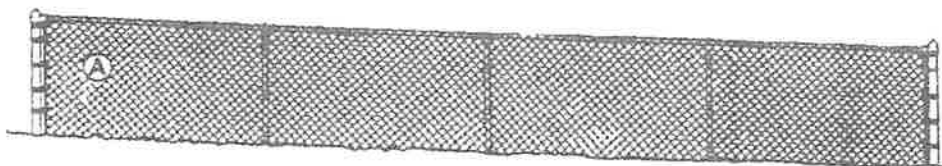

A Straight fence top, sloping terrain



B Fence following grade, rolling terrain

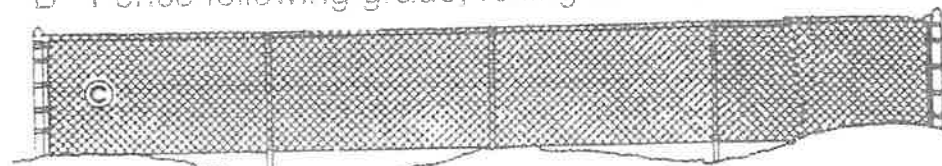

C Level fence top, rolling/uneven terrain

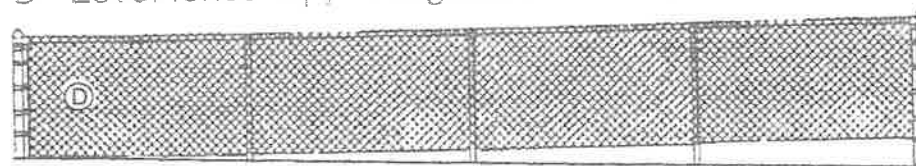

D Level fence top, sloping terrain



Privacy

Pools

Decorative

Protection

FENCE PROPOSAL/CONTRACT

DATE: <u>2-4-23</u>	PREPARED BY: <u>Tyler 321-696-9016</u>
NAME: <u>TRIAD ASSOCIATION MANAGEMENT</u>	CONTACT PHONE: <u>813-469-8491</u>
ADDRESS: <u>711 WEST MAIN ST.</u>	ALTERNATE PHONE:
CITY: <u>LEESBURG, FL. 34748</u>	CONTACT PERSON: <u>MADISON McADAMS</u>
E-MAIL: <u>MCMCADAMS@TRIADASSOC.MGMT.COM</u>	PHONE/ADDRESS:

JOB SPECIFICATIONS

JOB DIMENSIONS

- PVC (VINYL)
 ALUMINUM
 CHAIN LINK
 FARM FENCE
 COMPOSITE/SPECIALTY
 WOOD
 GATE AUTOMATION

NEXT TO JOB ADDRESS 4202 PIPKIN CREEK RD
PIPKIN CREEK ROAD

	OPTION #1
FOOTAGE	<u>183' TOTAL</u>
HEIGHT	<u>4' HIGH</u>
STYLE/MODEL	
GRADE	<u>RESIDENTIAL</u>
COLOR	<u>GALVANIZED</u>
ALL POSTS	
TERMINAL POSTS	<u>2 1/2"</u>
LINE POSTS	<u>1 5/8"</u>
GATE POSTS	
POST CAPS	<u>DOME / LOOP</u>
RAILS/RUNNERS	<u>1 3/8" TOP RAIL</u>
PICKETS	<u>==</u>
PICKET CAPS	<u>==</u>

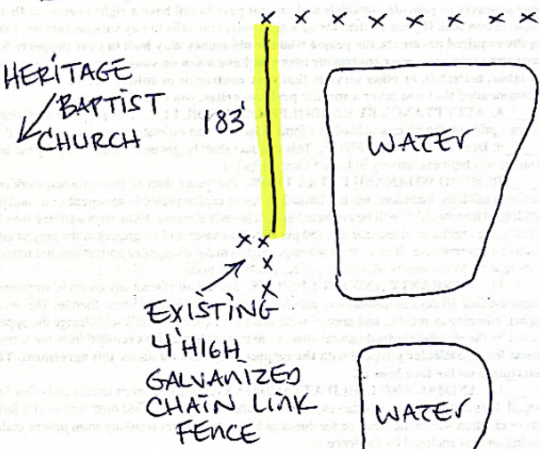

OPTIONS: PRE-STAINING COLOR: _____
FILL ONLY ONES THAT APPLY

GATES					
QTY	SIZE	TYPE	ARCHED	RACKED	SWING
<u>0</u>		<u>NO GATE</u>			

OPTIONS: Y or N

IMPORTANT PROJECT INFORMATION

FENCE TO FOLLOW CONTOUR OF GROUND
 STRAIGHT WITH GRADE DROP (MAY HAVE SOME GAPS)
 TOP LEVEL - HIGHEST GRADE (CUSTOMER TO FILL GAPS)
 TOP LEVEL - LOWEST GRADE (TRENCHING REQUIRED)
 REMOVAL & DISPOSAL OF EXISTING FENCE: _____ FT NO YES
 CLEARING OF FENCE LINE REQUIRED: YES NO
 CLEARING TO BE PERFORMED BY: INITIALS _____ OWNER RANDOLPH
 OPEN POOL / POOL CODE REQUIRED: YES NO
 HOA APPROVAL REQUIRED: YES NO
 PERMIT REQUIRED: YES NO
 JURISDICTION: _____

PLUS PERMIT FEE IF NEEDED

CONTRACT AMOUNT	<u>\$2767.⁰⁰</u>	DEPOSIT AMOUNT	<u>\$1384.⁰⁰</u>	BALANCE AMOUNT (DUE AT COMPLETION)	<u>\$1383.⁰⁰</u>
ACCEPTED BY CUSTOMER	<input checked="" type="checkbox"/>			DATE	

**LAKESIDE PRESERVE
COMMUNITY DEVELOPMENT DISTRICT**

Consideration of Proposal for
Pond Bank Low Spot Remediation



200 S. F. Street
Haines City, Florida 33844

Phone 863-422-5207 | Fax 863-422-1816

Polk County License # 214815

Date: March 3, 2023

SUBMITTED TO:

Lakeside Preserve CDD
4012 Shearwater St.
Lakeland FL, 33811
Madison McAdams
Phone: 813-469-8491
Email: mmcadams@triadassocmgmt.com

Job Name / Location:

Lakeside Preserve
4012 Shearwater St.
Lakeland, FL 33811

n retention pond behind 1432 Cypress Ln. We will also have to repair the area behind the homes that we track in and out

	Qty	Unit	Unit Cost	TOTAL
Dirt/grading	1	Each	\$3,750.00	\$3,750.00
Bahia Sod	9,600	Sqft	\$1.00	\$9,600.00
			Total:	\$13,350.00

The customer agrees, that by signing this proposal, it shall become a legal and binding contract and shall supersede any previous agreements, discussed or implied. The customer further agrees to all terms and conditions set forth within and shall be responsible for any/all court and/or attorney fees incurred by Prince and Sons, Inc. required to obtain collection for any portion of money owed for material and/or work performed by Prince and Sons Inc.

Submitted by: James Smith

Date Submitted: March 3, 2023

Accepted by: _____

Date Accepted: _____

**LAKESIDE PRESERVE
COMMUNITY DEVELOPMENT DISTRICT**

Consideration of Pond Fountain Option(s)



Font'N-Aire®

READY



FLOATING ONE-HORSEPOWER FOUNTAIN

READY AT A GLANCE

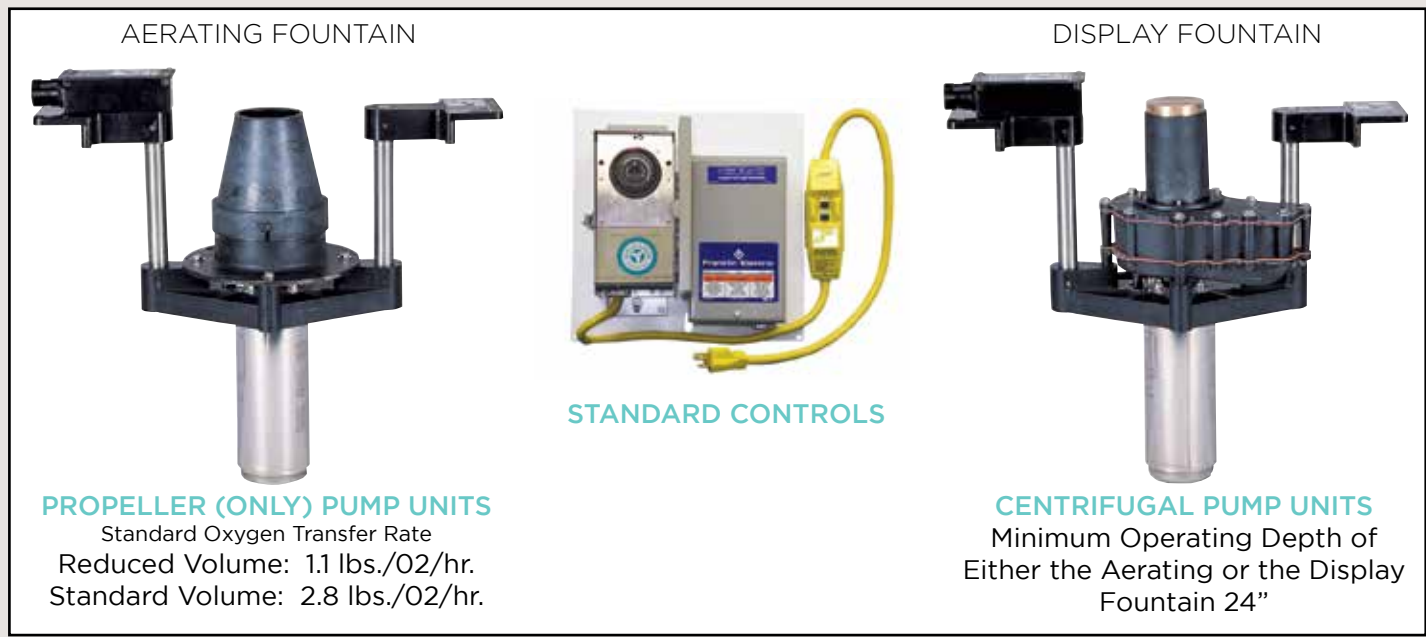

HOW IT WORKS

The Font’N-Aire Ready fountain line has four major components:

FLOAT - constructed of rugged polyethylene molded plastic with UV inhibitors and filled with non-hygroscopic pressure molded polystyrene foam.

POWER DRIVE ASSEMBLY - mounting structure (drive structure assembly), pump/propeller, nozzle and motor.

ELECTRICAL SERVICE CABLE ASSEMBLY - 100’ (standard) of AWG# 12/4 submersible cable and a submersible quick disconnect connector, which plugs into the fountain.

CONTROLS - 24-hour time clock with multiple off/on trippers, a Franklin Electric start and run QD capacitor box and an inline ELCI ground fault protector with a standard 230 volt, 15 amp plug. All of the components are prewired and mounted on a 16” x 14” plate.

Air-O-Lator exclusively uses the Franklin Electric 600M submersible motor on all fountain lines. The water cooled and lubricated motor is especially designed for lake and pond fountain applications and is environmentally safe.

The PROPELLER PUMP AERATING FOUNTAIN (with our scientifically engineered foul-resistant propeller) pumps 1,000 gallons of water per minute into the air through a specifically designed nozzle (Carnival). This causes the large column of water to shear into millions of micro droplets exposing more water to the atmosphere. As the aerated water returns to the parent body of water surface, turbulence is created in a 360 degree radius outward from the fountain increasing the interface of air to water, therefore transferring the atmospheric oxygen to the water.

The CENTRIFUGAL PUMP DISPLAY FOUNTAIN’s unique center discharge pump design keeps the shaft of the submersible motor and the discharge in a vertical position. This allows the entire weight of the fountain to remain in the center of the float. This also makes the fountain easy to install and remove from the float without special mounting brackets or hardware. Our centrifugal pump design produces high pressure, which creates terrific heights and displays using far less horsepower compared to other fountain equipment. This fountain should only be used for aesthetics because the volume of water being pumped into the air is not enough to be considered an aerating device by oxygen transfer testing and Air-O-Lator’s standards.

SPRAY PATTERNS AND PERFORMANCE DATA

MOTOR SPECIFICATIONS

Font'N-Aire Ready fountains are furnished with one-horsepower, 230 volt, 1 phase Franklin Electric motors. Each motor has a maximum amperage of 9.8 amps.



CARNIVAL PROPELLER PUMP			
STANDARD VOLUME		REDUCED VOLUME	
PART NO.	95RCR12301S	PART NO.	95RCR12301R
AVG HT	8	AVG HT	4
AVG DIA	25	AVG DIA	10
GPM	1000	GPM	400



DIANA CENTRIFUGAL PUMP			
STANDARD VOLUME		REDUCED VOLUME	
PART NO.	95RDA12301S	PART NO.	95RDA12301R
AVG HT	20	AVG HT	13
AVG DIA	20	AVG DIA	18
GPM	80	GPM	80



GALAXY CENTRIFUGAL PUMP			
STANDARD VOLUME		REDUCED VOLUME	
PART NO.	95RGL12301S	PART NO.	95RGL12301R
AVG HT	30	AVG HT	15
AVG DIA	50	AVG DIA	30
GPM	95	GPM	80



NORTHSTAR CENTRIFUGAL PUMP			
STANDARD VOLUME		REDUCED VOLUME	
PART NO.	95RNR12301S	PART NO.	95RNR12301R
AVG HT	16	AVG HT	14
AVG DIA	32	AVG DIA	28
GPM	108	GPM	80



NOVA CENTRIFUGAL PUMP			
STANDARD VOLUME		REDUCED VOLUME	
PART NO.	95RNV12301S	PART NO.	95RNV12301R
AVG HT	25	AVG HT	13
AVG DIA	N/A	AVG DIA	N/A
GPM	108	GPM	80



SOLACE CENTRIFUGAL PUMP			
STANDARD VOLUME		REDUCED VOLUME	
PART NO.	95RSL12301S	PART NO.	95RSL12301R
AVG HT	14	AVG HT	8
AVG DIA	18	AVG DIA	14
GPM	108	GPM	80



NOTE: G.P.M. is calculated through the nozzle selected.

*Running amperage will vary according to the nozzle selected, but at no time will the amperage exceed the maximum indicated per horsepower. Air-O-Lator Corporation's specifications as stated herein are the most current at the time of publication. However, consistent with Air-O-Lator Corporation's standard policy of continual product improvement, we reserve the right to change the design without notice or obligation on our part to modify any equipment previously sold or delivered.

TWO FOUNTAINS IN ONE

With the Ready fountain, it is possible to convert a centrifugal pump display fountain to a high volume propeller pump aerating fountain, or vice versa, without the need of purchasing two separate fountains. The design of the Font'N-Aire Ready and Platinum fountains allows this because the motor and mounting structure (drive structure assembly) are the same. When converting from a centrifugal pump display fountain to a propeller pump aerating fountain, simply remove the four (4) bolts that connect the centrifugal pump to the motor mount and remove the pump assembly. Install the propeller to the motor shaft and then the Carnival nozzle to the motor mount with four (4) bolts, a simple five-minute procedure that can be done in the field with a 7/16" wrench. The same procedure can be done to change a propeller pump aerating fountain to a centrifugal pump aesthetic fountain.

FEATURES

- Six spray patterns available
- Standard and Reduced volume options
- 100' of power cable with a water-tight removable connector, longer lengths available in 50' increments. [Required: a single phase, 3 wire w/ ground, 60 HZ, maximum length in feet, service entrance to fountain, 230 volts, 1hp, 400' 12/4 maximum]
- 24-hour time clock
- Equipment Leakage Circuit Interruptor (ELCI) (US only)
- Easy to install and maintain
- Two-year warranty
- Backed by our outstanding customer service

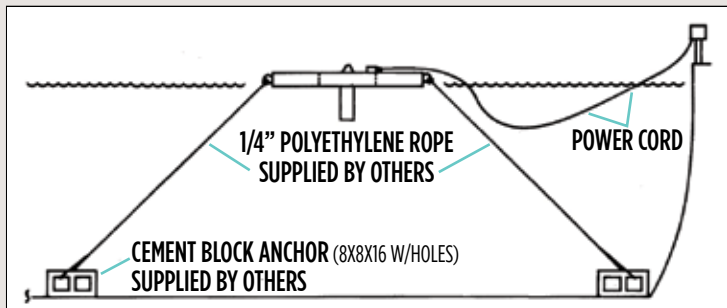

SUGGESTED MOORING

Use approximately three feet of mooring rope per foot of water depth to allow for water level fluctuation. Tying unit to the shore is also acceptable if visible mooring ropes are not objectionable.

OPTIONAL EQUIPMENT



ROCK FLOAT
(Shown with optional light kit installed)



LIGHTING KITS

- 12 volt, 200 watts photocell controlled lighting
- 4 (clear), 50 watt sealed beam lights (standard)
- Red, green, blue and amber lenses optional



ETL CONTROL PANEL
ANSI/UL508 control panel with time clock equipment leakage circuit interrupter (ELCI) and motor controls placed in a NEMA 4X enclosure

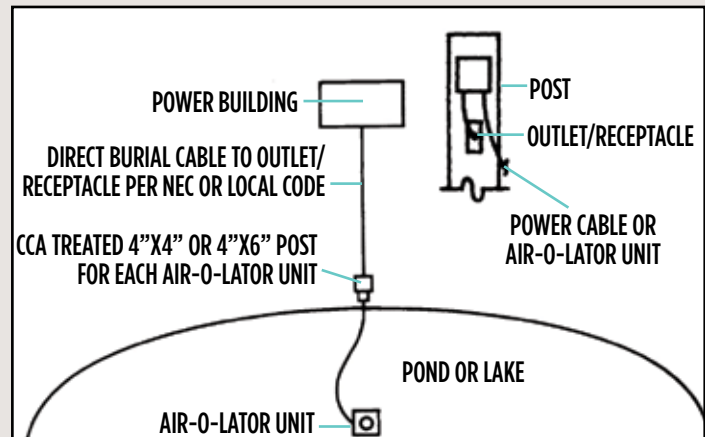

SUGGESTED ELECTRICAL

Our equipment is manufactured either to UL, CSA, NEMA standards. All wiring shall be per NEC, CEC, or local electric codes.



Font'N-Aire®

LEGACY



FLOATING 1/2 HP FOUNTAINS

LEGACY AT A GLANCE

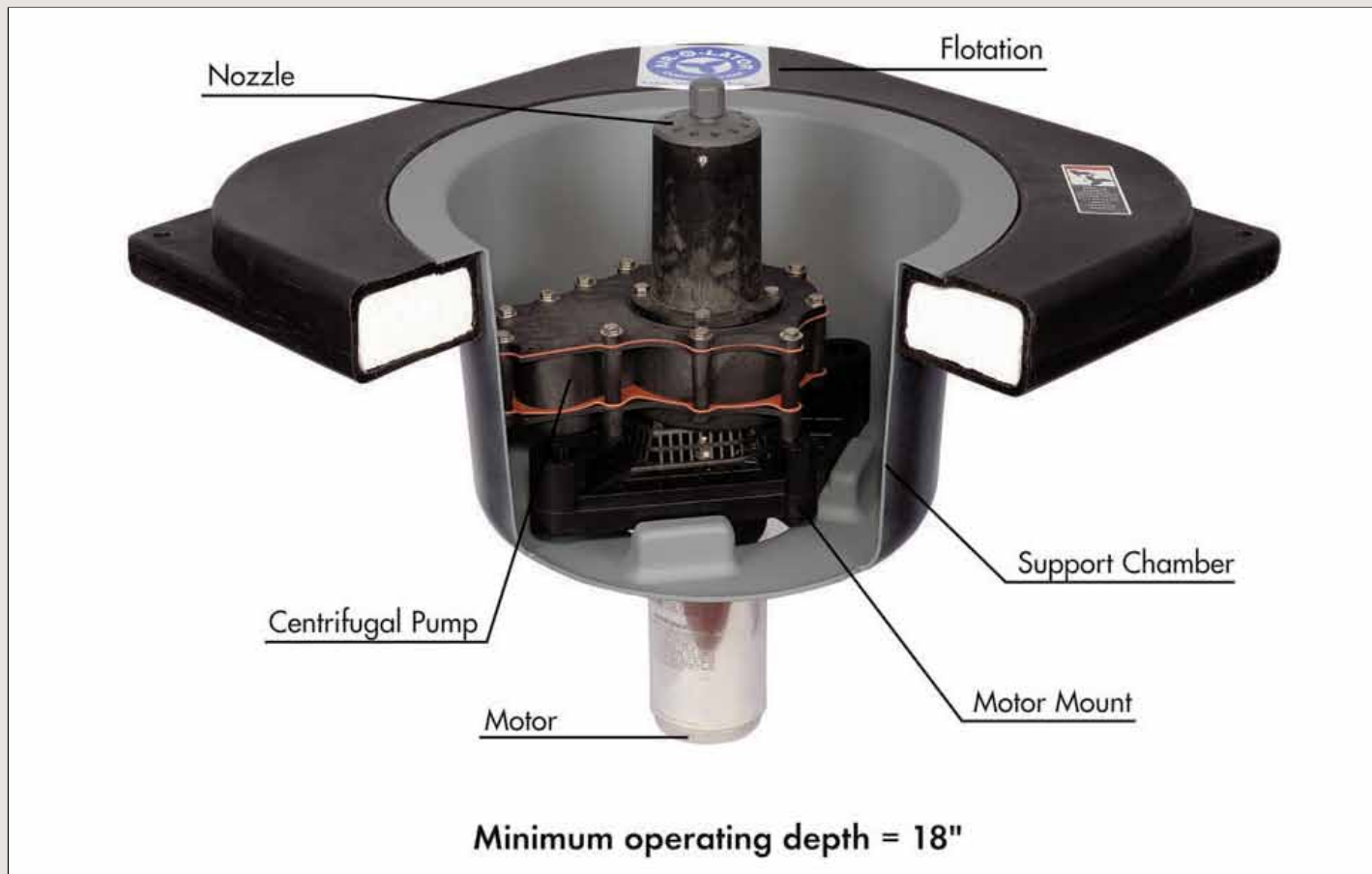

HOW IT WORKS

The Font'N-Aire Legacy fountain line has five major components:

FLOAT - constructed of rugged polyethylene molded plastic with UV inhibitors and filled with non-hygroscopic pressure molded polystyrene foam, measuring 24" x 24" with only 3" in thickness.

SUPPORT CHAMBER - holds the fountain in place on the flotation device.

POWER DRIVE ASSEMBLY - motor mount, centrifugal pump, nozzle and a motor.

ELECTRICAL SERVICE CABLE ASSEMBLY - 100' (standard) of AWG# 12/3 submersible cable.

TIMER - 24-hour time clock with multiple off/on trippers.

Air-O-Lator exclusively uses the Franklin Electric submersible motor on all fountain lines. The water cooled and lubricated motor is specially designed for lake and pond fountain applications and is environmentally safe.

The CENTRIFUGAL PUMP DISPLAY FOUNTAIN's unique center discharge pump design keeps the shaft of the submersible motor and the discharge in a vertical position. This allows the entire weight of the fountain to remain in the center of the float. This also makes the fountain easy to install and remove from the float without special mounting brackets or hardware. Our centrifugal pump design produces high pressure, which creates terrific heights and displays using far less horsepower compared to other fountain equipment. This fountain should only be used for aesthetics because the volume of water being pumped into the air is not enough to be considered an aerating device by oxygen transfer testing and Air-O-Lator's standards.

SPRAY PATTERNS AND PERFORMANCE DATA

LEGACY DISPLAY FOUNTAIN

PART NO. 96LG5115100

NOZZLE A WITHOUT CENTER JET



STANDARD VOLUME

AVG HT 4'
AVG DIA 12'
GPM 80

REDUCED VOLUME

AVG HT 2'
AVG DIA 6'
GPM 40

NOZZLE A WITH CENTER JET



STANDARD VOLUME

AVG HT 6'
AVG DIA 11'
GPM 80

REDUCED VOLUME

AVG HT 3'
AVG DIA 5'
GPM 40

NOZZLE B WITHOUT CENTER JET



STANDARD VOLUME

AVG HT 9'
AVG DIA 16'
GPM 80

REDUCED VOLUME

AVG HT 4'
AVG DIA 8'
GPM 40

NOZZLE B WITH CENTER JET



STANDARD VOLUME

AVG HT 9'
AVG DIA 16'
GPM 80

REDUCED VOLUME

AVG HT 4'
AVG DIA 8'
GPM 40

The Legacy performance characteristics can be modified for smaller areas. Simply remove the nozzle and plenum from the pump and insert the Flow Reduction Disc (FRD) into the plenum and reattach to the pump. The FRD reduces the spray pattern height and diameter by restricting the volume of water introduced into the nozzle.

ADVANTAGES:

- Stainless steel Franklin Electric water cooled and lubricated motor
- Eco-friendly motor (no oil required)
- Four spray patterns
- Flow Reduction Disc (FRD) to modify spray pattern height and diameter
- Modular design for ease of installation and service
- Time clock to control off/on operation
- Can be fitted with aftermarket nozzles
- 100' power cord
- Electric Leakage Circuit Interrupter (ELCI) for electrical safety (US only)
- Lightweight - Total shipping weight is 58 lbs.
- One-year warranty
- Backed by our outstanding customer service

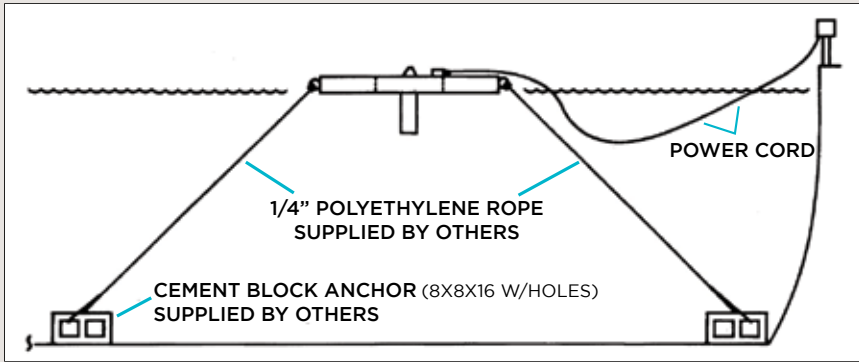

SUGGESTED MOORING

Use approximately three feet of mooring rope per foot of water depth to allow for water level fluctuation. Tying unit to the shore is also acceptable if visible mooring ropes are not objectionable.

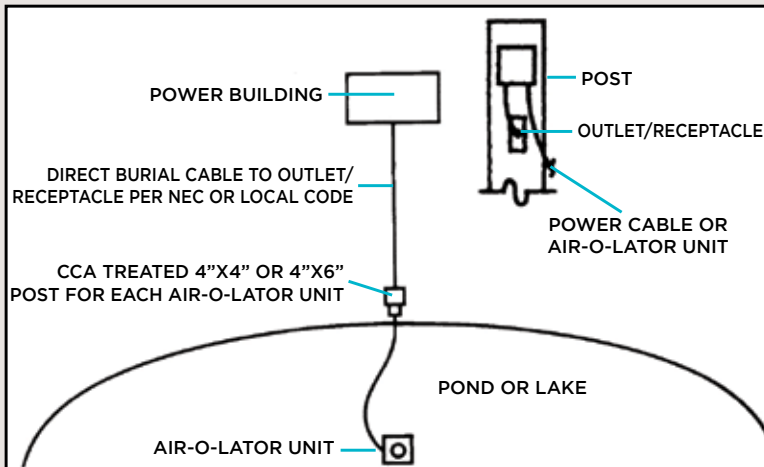

SUGGESTED ELECTRICAL

Our equipment is manufactured either to UL, CSA, or NEMA standards. All 1/2 hp units are designed to plug into an outlet; conduit wiring is permitted. All wiring shall be per NEC, CEC, or local electric codes.

OPTIONAL:



LIGHTING

A 12 volt, 105 watt lighting system with a photo cell controlled power transformer and 100' of lighting power cord are available for an additional cost.

New Line of Solar Fountains

Aerating Fountains

- Available in both 1/2 hp and 1 hp models
- Proprietary prop designed to maximize GPM and oxygen transfer
- Operates in only 18" of water for the 1/2hp and 24" for the 1hp
- No need for electricity - Solar powered
- Pumps up to 1,000 GPM for optimal aeration
- Everything included except mounting poles for the solar panels



Display Fountains

- Available in both 1/2hp and 1hp models
- Proprietary centrifugal pump designed for maximum display
- Operates in only 18" of water for the 1/2hp and 24" for the 1hp
- No need for electricity - Solar powered
- Choice of 5 nozzle patterns available
- 80 - 110 GPM output
- Everything included except mounting poles for the solar panels

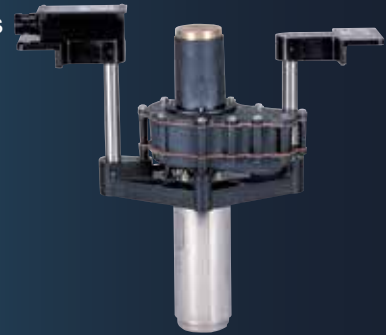

Solar Fountain Comparisons

	1/2 hp Aerating Fountain	1 hp Aerating Fountain	1/2 hp Display Fountain	1 hp Display Fountain
OWS Name	Aerify SW Solar	Aerify SW Solar	Palatial SW Solar	Palatial SW Solar
OWS Item #	SAF106	SAF054	SDF054	SDF106
Voltage	230v	230v	230v	230v
Pump Style	Propeller	Propeller	Centrifugal Pump	Centrifugal Pump
Motor	SS Franklin Water Cooled	SS Franklin Water Cooled	SS Franklin Water Cooled	SS Franklin Water Cooled
# of Nozzles Included	1	1	1	1
# of Nozzles Available	1	1	5	5
Solar Controller	1	1	1	1
Polystyrene Filled Float	36"	36"	36"	36"
Minimum Operating Depth	18"	24"	18"	24"
Solar Panels	4 - 36v Panels	6 - 36v Panels	4 - 36v Panels	6 - 36v Panels
Minimum Total Watts	1440+ Watts	2160+ Watts	1440+ Watts	2160+ Watts
Total Panel Measurements	156" W x 77" H	234" W x 77" H	156" W x 77" H	234" W x 77" H
Standard Power Cord	100'	100'	100'	100'
Max Power Cord Length	300'	300'	300'	300'
Fountain Warranty	2 years	2 years	2 years	2 years
Solar Panel Warranty	15 years	15 years	15 years	15 years
Operating Times	Daylight Hours	Daylight Hours	Daylight Hours	Daylight Hours
Racking Included	Yes	Yes	Yes	Yes
Mounting Poles Included	No	No	No	No
GPM Rating	500	1000	40	80

LAKESIDE PRESERVE COMMUNITY DEVELOPMENT DISTRICT

Consideration of Payment Authorizations
159, 163, 165 and 167

Lakeside Preserve
COMMUNITY DEVELOPMENT DISTRICT

Payment Authorization No. 159

1/15/2023

Item No.	Vendor	Invoice Number	FY23 General Fund
1	CA Florida Holding, LLC Legal Ad 10/4/2022	0005037302	\$ 285.24
2	Joe G Tedder, CFC Mailing 2022 Tax notices	--	\$ 28.01
3	Landmark Engineering Stormwater Analysis	2170075-13	\$ 150.00
	Stormwater Analysis	2170075-14	\$ 395.00
4	PFM Group Consulting DM Fees - January 2023	DM-01-2023-22	\$ 2,291.67
5	Prince & Sons Inc Irrigation	7763	\$ 73.75
	Landscape Maintenance January 2023	7702	\$ 4,265.00
6	Lakeland Electric Utility	3591280	\$ 22.33
	Utility	3591279	\$ 57.41
7	VGlobalTech Monthly Website Fee	4473	\$ 135.00
	Monthly Website Fee	4598	\$ 135.00
			\$ 7,838.41
TOTAL			\$ 7,838.41

District Manager

Board Member

Please Return To:
Lakeside Preserve CDD
c/o PFM Group Consulting
3501 Quadrangle Blvd, Suite 270
Orlando, FL 32817



The Daytona Beach News-Journal
Daytona Pennysaver

ACCOUNT NAME	ACCOUNT #	PAGE #
Pioneer Community Dev Dist	464726	1 of 1

INVOICE #	BILLING PERIOD	PAYMENT DUE DATE
0005037302	Oct 1- Oct 31, 2022	November 20, 2022
PREPAY (Memo Info)	UNAPPLIED (included in amt due)	TOTAL AMOUNT DUE
\$0.00	\$0.00	\$742.72

BILLING ACCOUNT NAME AND ADDRESS	BILLING INQUIRIES/ADDRESS CHANGES	FEDERAL ID
Pioneer Community Dev Dist 12051 Corporate Blvd. Orlando, FL 32817-1450 	1-877-736-7612 or smb@ccc.gannett.com	47-2390983
<p>Legal Entity: Gannett Media Corp. Terms and Conditions: Past due accounts are subject to interest at the rate of 18% per annum or the maximum legal rate (whichever is less). Advertiser claims for a credit related to rates incorrectly invoiced or paid must be submitted in writing to Publisher within 30 days of the invoice date or the claim will be waived. Any credit towards future advertising must be used within 30 days of issuance or the credit will be forfeited. All funds payable in US dollars.</p>		

0000464726000000000000000050373020007427267241

Starting in October ad placements will be assessed a monthly creative processing fee to cover fees associated with award winning ad design, toning, imaging, and sizing. Previous Account Number: **DBN_1008633**

Date	Description	Amount
10/1/22	Balance Forward	\$280.72

Package Advertising:

Start-End Date	Order Number	Description	PO Number	Package Cost
10/4/22	7864247	FISCAL YEAR 2023 Lakeside Preserve per attached proof		\$285.24
10/10/22	7828502	Notice of Meetings		\$176.76

RECEIVED
By M. Magar at 4:31 pm, Nov 14, 2022

PLEASE DETACH AND RETURN THIS PORTION WITH YOUR PAYMENT



The Daytona Beach News-Journal
Daytona Pennysaver

ACCOUNT NAME	PAYMENT DUE DATE	AMOUNT PAID
Pioneer Community Dev Dist	November 20, 2022	
ACCOUNT NUMBER	INVOICE NUMBER	
464726	0005037302	

CURRENT DUE	30 DAYS PAST DUE	60 DAYS PAST DUE	90 DAYS PAST DUE	120+ DAYS PAST DUE	UNAPPLIED PAYMENTS	TOTAL AMOUNT DUE
\$462.00	\$280.72	\$0.00	\$0.00	\$0.00	\$0.00	\$742.72

REMITTANCE ADDRESS (Include Account# & Invoice# on check)	TO PAY WITH CREDIT CARD PLEASE FILL OUT BELOW:
Daytona Beach News-Journal P.O. Box 630476 Cincinnati, OH 45263-0476	<input type="checkbox"/> VISA <input type="checkbox"/> MASTERCARD <input type="checkbox"/> DISCOVER <input type="checkbox"/> AMEX Card Number _____ Exp Date ____/____/____ CVV Code _____ Signature _____ Date _____

0000464726000000000000000050373020007427267241

PROOF OF PUBLICATION

PIONEER COMMUNITY DEV DISTRICT PIONEER
COMMUNITY DEV DIST
Pioneer Community Dev Dist
12051 Corporate BLVD
Orlando FL 32817-1450

STATE OF WISCONSIN, COUNTY OF BROWN

Before the undersigned authority personally appeared, said legal clerk, who, on oath says that he/she is LEGAL COORDINATOR of The News-Journal, a daily and Sunday newspaper, published at Daytona Beach in Volusia and Flagler Counties, Florida; that the attached copy of advertisement, being a Public Notices in the Circuit Court, was published in said newspaper in the issues dated or by publication on the newspaper's website, if authorized, on:

10/04/2022

Affiant further says that The News-Journal is a newspaper published at Daytona Beach, in said Volusia County, Florida, and that the said newspaper has heretofore been continuously published in said Volusia County, Florida each day and Sunday and has been entered as second-class mail matter at the post office in Daytona Beach, in said Volusia County, Florida, for a period of one year next preceding the first publication of the attached copy of advertisement; and affiant further says that he has neither paid nor promised any person, firm or corporation any discount, rebate, commission or refund for the purpose of securing this advertisement for publication in the said newspaper. Subscribed and sworn to before on 10/04/2022



Legal Clerk

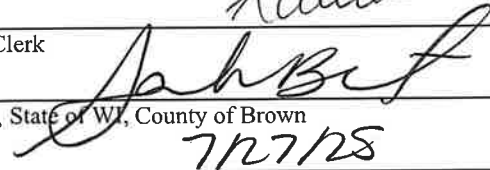

Notary, State of WI, County of Brown
7/27/25

My commission expires

Publication Cost: \$285.24

Order No: 7864247

Customer No: 464726

PO #:

THIS IS NOT AN INVOICE!

Please do not use this form for payment remittance.

of Copies:

1

SARAH BERTELSEN
Notary Public
State of Wisconsin

**NOTICE OF BOARD OF SUPERVISORS MEETING DATES
LAKESIDE PRESERVE COMMUNITY DEVELOPMENT DISTRICT
FISCAL YEAR 2023**

The Board of Supervisors of the Lakeside Preserve Community Development District will hold the regular meetings for the Fiscal Year 2022-2023 at the Offices of Highland Homes, 3020 S. Florida Avenue, Suite 101, Lakeland Florida 33803 at 11:30 a.m., unless otherwise indicated, as follows:

- October 19, 2022
- November 16, 2022
- December 21, 2022
- January 18, 2023
- February 15, 2023
- March 15, 2023
- April 19, 2023
- May 17, 2023
- June 21, 2023
- July 19, 2023
- August 16, 2023
- September 20, 2023

The meetings are open to the public and will be conducted in accordance with the provision of Florida Law for Community Development Districts. The meetings may be continued to a date, time, and place to be specified on the record at the meeting. A copy of the agenda may be obtained at the offices of the District Manager, c/o PFM Group Consulting, LLC, 3501 Quadrangle Boulevard, Suite 270, Orlando, Florida 32817 or by calling (407) 723-5900.

There may be occasions when one or more Supervisors or staff will participate by telephone. Pursuant to provisions of the Americans with Disabilities Act, any person requiring special accommodations at this meeting because of a disability or physical impairment should contact the District Office at (407) 723-5900 at least 48 hours prior to the meeting. If you are hearing or speech impaired, please contact the Florida Relay Service by dialing 7-1-1, or 1-800-955-8771 (TTY) / 1-800-955-8770 (Voice), for aid in contacting the District Office.

A person who decides to appeal any decision made at the meeting with respect to any matter considered at the meeting is advised that person will need a record of the proceedings and that accordingly, the person may need to ensure that a verbatim record of the proceedings is made, including the testimony and evidence upon which such appeal is to be based.

District Manager

October 10th, 2022



8515 Palm River Road, Tampa, FL 33619-4315 | 813-621-7841 | Fax 813-621-6761 | mail@lesc.com | www.lesc.com

RECEIVED

By Verona Griffith at 10:09 pm, Jan 02, 2023

Invoice

Ms. Jane Gaarlandt
c/o PFM Group Consulting LLC
12051 Corporate Blvd
Orlando, FL 32817

Invoice Date: Nov 15, 2022
Invoice No: 2170075-13
Billing Through: Oct 31, 2022

Lakeside Preserve CDD (2170075:)

Phase ID	Phase Description	Contract Amount	% Complete	Contract Billed To Date	Current Services
1.2-DE	District Engineer				\$150.00
	Prepare For & Attend (Virtually) October 18 Board Meeting				
	<u>Description</u>	<u>Hours</u>	<u>Rate</u>	<u>Amount</u>	
	Senior Professional Engineer	1.00	\$150.00	\$150.00	

Amount Due This Invoice: \$150.00



8515 Palm River Road, Tampa, FL 33619-4315 | 813-621-7841 | Fax 813-621-6761 | mail@lesc.com | www.lesc.com

RECEIVED
By Verona Griffith at 7:59 am, Jan 03, 2023

Invoice

Ms. Jane Gaarlandt
c/o PFM Group Consulting LLC
12051 Corporate Blvd
Orlando, FL 32817

Invoice Date: Dec 15, 2022
Invoice No: 2170075-14
Billing Through: Nov 30, 2022

Lakeside Preserve CDD (2170075:)

Phase ID	Phase Description	Contract Amount	% Complete	Contract Billed To Date	Current Services
1.2-DE	District Engineer				\$395.00
	Site Meeting to Review Grading Issue and Pond Erosion; Coordinate with Staff on Same				
	<u>Description</u>	<u>Hours</u>	<u>Rate</u>	<u>Amount</u>	
	Senior Professional Engineer	1.50	\$150.00	\$225.00	
	Inspector	2.00	\$85.00	\$170.00	

Amount Due This Invoice: \$395.00

PRINCE & SONS, INC.

200 South F Street
Haines City, FL 33844



Invoice

DATE	INVOICE NO.
1/1/2023	7702

BILL TO
Lakeside Preserve-Lakeland Lakeside Preserve CDD c/o PFM Group Consulting, LLC 12051 Corporate Blvd. Orlando, Florida 32817

PLACE OF SERVICE
Lakeside Preserve-Lakeland 4006 Shearwater Street Lakeland, Florida 33811

RECEIVED
By Verona Griffith at 12:22 pm, Jan 03, 2023

TERMS	DUE DATE	P&S WO#	Rep	Vendor PO #
Net 30	1/31/2023			

DESCRIPTION	Quantity	RATE	AMOUNT
January Landscape Maintenance	1	3,675.00	3,675.00
Horticulture	1	350.00	350.00
Irrigation Inspection	1	240.00	240.00

Phone #	E-mail Accounts@princeandsonsinc.com	Total	\$4,265.00
		Payments/Credits	\$0.00
8634225207	Web Site www.Princeandsonsinc.com	Balance Due	\$4,265.00

PRINCE & SONS, INC.

200 South F Street
Haines City, FL 33844



Invoice

DATE	INVOICE NO.
1/3/2023	7763

BILL TO
Lakeside Preserve-Lakeland Lakeside Preserve CDD c/o PFM Group Consulting, LLC 12051 Corporate Blvd. Orlando, Florida 32817

PLACE OF SERVICE
Lakeside Preserve-Lakeland 4006 Shearwater Street Lakeland, Florida 33811

RECEIVED
By Verona Griffith at 12:40 pm, Jan 05, 2023

TERMS	DUE DATE	P&S WO#	Rep	Vendor PO #
Net 30	2/2/2023			

DESCRIPTION	Quantity	RATE	AMOUNT
Irrigation Labor--Replace clogged or broken nozzles, spray head. Repaired cut bubbler line.	1	65.00	65.00
Hunter Nozzles	4	1.87	7.48
1/2" Coupling	1	0.55	0.55
1/2" MA90	1	0.72	0.72

Phone #	E-mail Accounts@princeandsonsinc.com	Total	\$73.75
		Payments/Credits	\$0.00
8634225207	Web Site www.Princeandsonsinc.com	Balance Due	\$73.75



Date	Invoice Number
January 3, 2023	DM-01-2023-22
Payment Terms	Due Date
Upon Receipt	January 3, 2023

Bill To:
Lakeside Preserve Community Development District
c/o PFM Group Consulting District Accounting
Department
3501 Quadrangle Blvd., Suite 270
Orlando, FL 32817
United States of America

Company Address:
1735 Market Street
42nd Floor
Philadelphia, PA 19103
+1 (215) 5676100

Remittance Options:

Via Mail:

PFM Group Consulting LLC
PO Box 65126
Baltimore, MD 21264-5126
United States of America

RE: District Management Fee: January 2023

Professional Fees

\$2,291.67

Total Amount Due

\$2,291.67



Joe G. Tedder, CFC
430 E Main Street, Bartow, FL 33830
Finance Department (863)534-4719

Amanda Lane
3501 Quadrangle Blvd, Suite 270
Orlando, FL 32817

January 2, 2023

		Amount Due
Allocation of postage costs for mailing 2022 tax notices per Section 197.322 (3), F.S.		
LAKESIDE LANDINGS CDD	\$83.23	
LAKESIDE PRESERVE CDD	\$28.01	
INVOICE		
TOTAL		111.25
 Stephen Zarycki, Chief Financial Officer		
Please pay via ACH to our bank account number ending in 9516.		



LAKESIDE PRESERVE COMMUNITY DEVELOPMENT DISTRICT
4000 PIPKIN CREEK RD # ENTR
LAKELAND FL 33811 US

Account # 3591280

Due Date	Amount Due
01/30/2023	\$22.33

Bill Summary

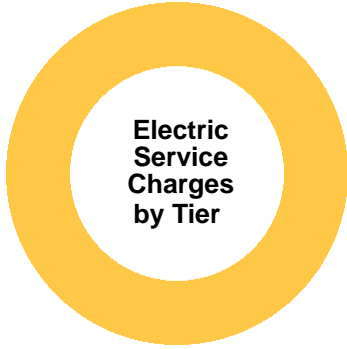

72 kWh @ 0.05015 \$3.61

For a more detailed explanation of rates and charges, please see reverse side.

Billing Date: 01/02/2023

Previous Bill	\$21.71
Payments/Credits/Returns since 12/01/2022	\$-22.13
Balance Forward	-\$0.42
Electric Service Charges	\$22.75
Total Current Charges	\$22.75
Total Amount Due by 01/30/2023	\$22.33

Billing details located on following page(s) ▶

Contact Us

- ⚡💧 Electric / Water Billing Inquiries 863-834-9535
- ♻️🗑️ Wastewater / Solid Waste Billing..... 863-834-8276
- ⚡🚰 Fallen Power Lines / Water Outages..... 863-834-4248
- 🚓 False Alarms (Lakeland Police Dept) 863-834-6940
- 🚒 Miscellaneous Fire Dept Billings..... 863-834-8201
- ⚡ 24-Hour Power Outage Reporting..... 866-834-4248
- 💰 24-Hour Payment Hotline 863-834-9535
- 👤 TDD (For Hearing Impaired)..... 863-834-8333
- ♻️ Recycling..... 863-834-8774
- ⚡ Surge Protection..... 863-834-1500

Message Center

🖥️ Online: lakelandelectric.com

✉️ Mail: P.O. Box 32006 Lakeland, FL 33802-2006

📞 Phone: (863) 834-9535

08

Please return this stub along with your payment and note the account number on your check or money order to ensure proper credit to your account.



Account #
3591280

Due Date	Amount Due
01/30/2023	\$22.33

\$

USD Amount Enclosed

LAKESIDE PRESERVE COMMUNITY DEVELOPMENT DISTRICT
12051 CORPORATE BLVD
ORLANDO FL 32817

VISIT OUR EZPAY KIOSKS
Payments will post to your account immediately.

Scan this QR code at our
EZPay Kiosk
to go directly to your account

Please see back of stub for kiosk locations.

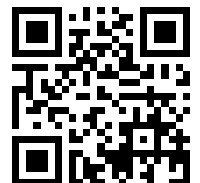

0 000000000002233 000000035912807 0 000000000002233 000000035912807

Account # **3591280**

Bill Detail

Electric Service

Meter Number	No. of Days	Unit of Measure	Current Month	Previous Month	Last Year
322556	32	kWh	72	67	82

Meter Reading Dates: 11/30/2022 to 01/01/2023

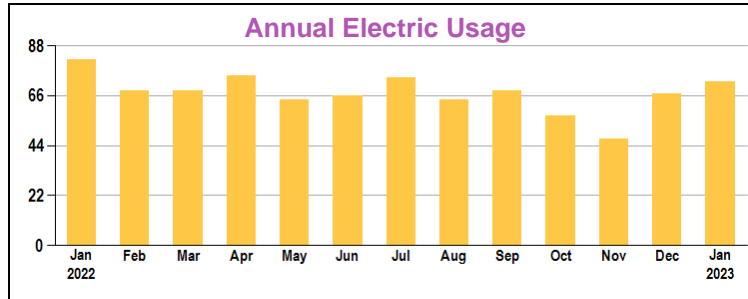

General Service Customer Charge	\$13.00
Electric 72 KWH @ 0.05015	\$3.61
Environmental Charge 72 KWH @ 0.0024097	\$0.17
Fuel Charge 72 KWH @ 0.075	\$5.40
Florida Gross Receipts Tax	\$0.57

Current Electric Service Charges \$22.75

All balances are subject to penalty if paid after the due date, please see summary of all charges on Page 1 of your bill.

Running a business isn't easy, but choosing the right price plan can be. It only takes minutes with our price plan comparison tool.

TRY IT NOW AT

LAKELANDELECTRIC.COM/ENERGYTOOLSET



The City of Lakeland collects social security numbers for the following purposes: account classification; customer identification; verification; billing; payment; creditworthiness; and any lawful purposes in the conduct of City of Lakeland business.

Address Change

There are several ways to change your mailing address!

- Visit lakelandelectric.com/MyAccount
- Email us at customerservice@lakelandelectric.com
- Call us at 863-834-9535

Our call center hours are, Monday - Friday from 7:30 a.m. to 6:00 p.m.

EZPay Kiosk Locations

Drive-Through Kiosk
Lakeland Electric - 501 E. Lemon Street

Walk-Up Kiosk
Larry R Jackson Library - 1700 N. Florida Ave.
Kelly Recreation Center - 404 Imperial Blvd.
Town Center - 989 E Memorial Blvd.

All payments made at the kiosk post to your account in real-time!



LAKESIDE PRESERVE COMMUNITY DEVELOPMENT DISTRICT
 4115 LAKESIDE PRESERVE BL # WELL
 LAKELAND FL 33811 US

Account # **3591279**

Due Date	Amount Due
01/30/2023	\$57.41

Bill Summary

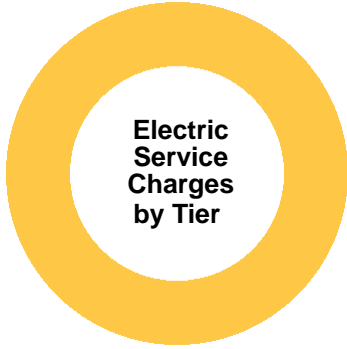

340 kWh @ 0.05015 \$17.05

For a more detailed explanation of rates and charges, please see reverse side.

Billing Date: 01/02/2023

Previous Bill	\$71.29
Payments/Credits/Returns since 12/01/2022	\$-71.71
Balance Forward	\$-0.42
Electric Service Charges	\$57.83
Total Current Charges	\$57.83
Total Amount Due by 01/30/2023	\$57.41

Billing details located on following page(s) ▶

Contact Us

- Electric / Water Billing Inquiries 863-834-9535
- Wastewater / Solid Waste Billing..... 863-834-8276
- Fallen Power Lines / Water Outages..... 863-834-4248
- False Alarms (Lakeland Police Dept) 863-834-6940
- Miscellaneous Fire Dept Billings..... 863-834-8201
- 24-Hour Power Outage Reporting..... 866-834-4248
- 24-Hour Payment Hotline 863-834-9535
- TDD (For Hearing Impaired)..... 863-834-8333
- Recycling..... 863-834-8774
- Surge Protection..... 863-834-1500

Message Center

Online: lakelandelectric.com

Mail: P.O. Box 32006 Lakeland, FL 33802-2006

Phone: (863) 834-9535

08

Please return this stub along with your payment and note the account number on your check or money order to ensure proper credit to your account.



Account #
3591279

Due Date	Amount Due
01/30/2023	\$57.41

\$

USD Amount Enclosed

LAKESIDE PRESERVE COMMUNITY DEVELOPMENT DISTRICT
12051 CORPORATE BLVD
ORLANDO FL 32817

VISIT OUR EZPAY KIOSKS
Payments will post to your account immediately.

Scan this QR code at our
EZPay Kiosk
to go directly to your account

Please see back of stub for kiosk locations.

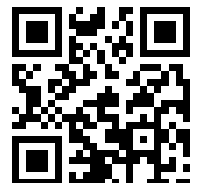

0 000000000005741 000000035912799 0 000000000005741 000000035912799

Account # **3591279**

Bill Detail

Electric Service

Meter Number	No. of Days	Unit of Measure	Current Month	Previous Month	Last Year
405780	32	kWh	340	446	66

Meter Reading Dates: 11/30/2022 to 01/01/2023

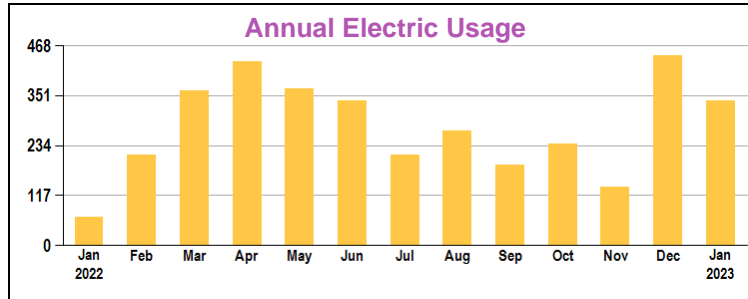

General Service Customer Charge	\$13.00
Electric 340 KWH @ 0.05015	\$17.05
Environmental Charge 340 KWH @ 0.0024097	\$0.82
Fuel Charge 340 KWH @ 0.075	\$25.50
Florida Gross Receipts Tax	\$1.45
Florida Regulatory Commission Surcharge	\$0.01

Current Electric Service Charges \$57.83

All balances are subject to penalty if paid after the due date, please see summary of all charges on Page 1 of your bill.

Running a business isn't easy, but choosing the right price plan can be. It only takes minutes with our price plan comparison tool.

TRY IT NOW AT

LAKELANDELECTRIC.COM/ENERGYTOOLSET



The City of Lakeland collects social security numbers for the following purposes: account classification; customer identification; verification; billing; payment; creditworthiness; and any lawful purposes in the conduct of City of Lakeland business.

Address Change

There are several ways to change your mailing address!

- Visit lakelandelectric.com/MyAccount
- Email us at customerservice@lakelandelectric.com
- Call us at 863-834-9535

Our call center hours are, Monday - Friday from 7:30 a.m. to 6:00 p.m.

EZPay Kiosk Locations

Drive-Through Kiosk
Lakeland Electric - 501 E. Lemon Street

Walk-Up Kiosk
Larry R Jackson Library - 1700 N. Florida Ave.
Kelly Recreation Center - 404 Imperial Blvd.
Town Center - 989 E Memorial Blvd.

All payments made at the kiosk post to your account in real-time!

VGlobalTech
636 Fanning Drive
Winter Springs, FL 32708 US
contact@vglobaltech.com
www.vglobaltech.com



INVOICE

BILL TO

Lakeside Preserve CDD
3501 Quadrangle Blvd.,
Suite 270,
Orlando, FL 32817

INVOICE # 4598

DATE 12/01/2022

DUE DATE 12/01/2022

TERMS Due on receipt

DATE	ACTIVITY	QTY	RATE	AMOUNT
	Web Maintenance:ADA Website Maintenance Ongoing website maintenance for ADA and WCAG Compliance	1	135.00	135.00

Please make checks payable to "VGlobalTech"

BALANCE DUE

\$135.00

VGlobalTech
636 Fanning Drive
Winter Springs, FL 32708 US
contact@vglobaltech.com
www.vglobaltech.com



INVOICE

BILL TO

Lakeside Preserve CDD
3501 Quadrangle Blvd.,
Suite 270,
Orlando, FL 32817

INVOICE # 4473

DATE 11/01/2022

DUE DATE 11/01/2022

TERMS Due on receipt

DATE	ACTIVITY	QTY	RATE	AMOUNT
	Web Maintenance:ADA Website Maintenance Ongoing website maintenance for ADA and WCAG Compliance	1	135.00	135.00

Please make checks payable to "VGlobalTech"

BALANCE DUE

\$135.00

Lakeside Preserve
COMMUNITY DEVELOPMENT DISTRICT

Payment Authorization No. 163

3/9/2023

Item No.	Vendor	Invoice Number	FY23 General Fund
1	Kilinski Van Wyk, PLLC General Counsel	5785	\$ 462.22
2	Lerner Raeporing Services, Inc. Lakeside Preserve CDD FY23 Annual Disclosure Fee	317	\$ 5,000.00
3	PFM Group Consulting Postage Jan 2023	OE-EXP-02-0023-23	\$ 2.28
4	Prince & Sons Inc Irrigation	8089	\$ 179.17
	Landscape Maintenance March 2023	8198	\$ 4,265.00
5	Lakeland Electric Utility	3591280	\$ 18.71
	Utility	3591279	\$ 42.08
6	Solitude Lake Management Dec pond management service	PSI-31624	\$ 847.68
	January pond management service	PSI-41367	\$ 847.68
	March pond management service	PSI-55723	\$ 847.68
			\$ 12,512.50
TOTAL			\$ 12,512.50

District Manager/

Board Member

Please Return To:
Lakeside Preserve CDD
c/o PFM Group Consulting
3501 Quadrangle Blvd, Suite 270
Orlando, FL 32817



RECEIVED

By Verona Griffith at 5:56 pm, Feb 22, 2023

INVOICE

KILINSKI | VAN WYK

Kilinski | Van Wyk, PLLC

P.O. Box 6386
Tallahassee, Florida 32314

Invoice # 5785
Date: 02/21/2023
Due On: 03/23/2023

Lakeside Preserve CDD
12051 Corporate Boulevard
Orlando, Florida 32817

LSPCDD-01

LAKESIDE PRESERVE CDD – GENERAL COUNSEL

Type	Professional	Date	Notes	Quantity	Rate	Total
Service	RVW	01/18/2023	Confer with staff regarding phase 2. Confer with Walsh regarding resident request regarding fence.	0.60	\$365.00	\$219.00
Service	RVW	01/19/2023	Draft response to resident e-mail and confer with Walsh regarding same.	0.40	\$365.00	\$146.00
Expense	AL	01/20/2023	UPS: UPS Shipping	1.00	\$5.84	\$5.84
Expense	AL	01/20/2023	UPS: UPS Shipping	1.00	\$9.75	\$9.75
Expense	AL	01/30/2023	Mileage: Mileage for meeting-LG	72.20	\$0.625	\$45.13
Service	RVW	01/31/2023	Monitor legislative activity for impact on special districts.	0.10	\$365.00	\$36.50
					Total	\$462.22

Detailed Statement of Account

Current Invoice

Invoice Number	Due On	Amount Due	Payments Received	Balance Due
5785	03/23/2023	\$462.22	\$0.00	\$462.22
			Outstanding Balance	\$462.22

Total Amount Outstanding \$462.22

Please make all amounts payable to: Kilinski | Van Wyk, PLLC

Please pay within 30 days.

Invoice

Lerner Reporting Services, Inc.
5711 Yeats Manor Dr, #401
Tampa, FL 33616
(813) 786-2094

Date	Invoice #
12/13/2022	317

Bill To
Lakeside Preserve CDD Attn: Jane Gaarlandt Gaarlandtj@pfm.com

RECEIVED
By Verona Griffith at 12:30 pm, Feb 17, 2023

P.O. No.	Terms	Project

Quantity	Description	Amount
	Lakeside Preserve CDD FY23 Annual Disclosure Fee	5,000.00

Total	\$5,000.00
--------------	------------

Please wire to:
Valley National Bank
P.O. Box 558
Wayne, NJ 07474-0558
Routing #: 021201383
Lerner Reporting Services, Inc.
Account #: 5000074414

Or mail to:
5711 Yeats Manor Drive, # 401
Tampa, FL 33616
Direct all questions to:
Leah Popelka
lpopelka@lerneradvisors.com
(813) 786-2094

PRINCE & SONS, INC.

200 South F Street
Haines City, FL 33844



Invoice

DATE	INVOICE NO.
2/13/2023	8089

BILL TO
Lakeside Preserve-Lakeland Lakeside Preserve CDD c/o PFM Group Consulting, LLC 12051 Corporate Blvd. Orlando, Florida 32817

PLACE OF SERVICE
Lakeside Preserve-Lakeland 4006 Shearwater Street Lakeland, Florida 33811

RECEIVED
By Verona Griffith at 10:55 am, Feb 13, 2023

TERMS	DUE DATE	P&S WO#	Rep	Vendor PO #
Net 30	3/15/2023			

DESCRIPTION	Quantity	RATE	AMOUNT
Irrigation Labor--Replaced clogged or broken nozzles and broken heads.	2	65.00	130.00
Hunter Spray Nozzles	6	1.87	11.22
Hunter 6" Spray Heads	3	12.65	37.95

Phone #	E-mail Accounts@princeandsonsinc.com	Total	\$179.17
		Payments/Credits	\$0.00
8634225207	Web Site www.Princeandsonsinc.com	Balance Due	\$179.17

PRINCE & SONS, INC.

200 South F Street
Haines City, FL 33844



Invoice

DATE	INVOICE NO.
3/1/2023	8198

BILL TO
Lakeside Preserve-Lakeland Lakeside Preserve CDD c/o PFM Group Consulting, LLC 12051 Corporate Blvd. Orlando, Florida 32817

PLACE OF SERVICE
Lakeside Preserve-Lakeland 4006 Shearwater Street Lakeland, Florida 33811

TERMS	DUE DATE	P&S WO#	Rep	Vendor PO #
Net 30	3/31/2023			

DESCRIPTION	Quantity	RATE	AMOUNT
March Landscape Maintenance	1	3,675.00	3,675.00
Horticulture	1	350.00	350.00
Irrigation Inspection	1	240.00	240.00

RECEIVED
By Verona Griffith at 1:31 pm, Mar 03, 2023

Phone #		Total	\$4,265.00
	E-mail Accounts@princeandsonsinc.com	Payments/Credits	\$0.00
8634225207	Web Site www.Princeandsonsinc.com	Balance Due	\$4,265.00



Date	Invoice Number
February 21, 2023	OE-EXP-02-2023-23
Payment Terms	Due Date
Upon Receipt	February 21, 2023

Bill To:
Lakeside Preserve Community Development District
c/o PFM Group Consulting District Accounting
Department
3501 Quadrangle Blvd., Suite 270
Orlando, FL 32817
United States of America

Company Address:
1735 Market Street
42nd Floor
Philadelphia, PA 19103
+1 (215) 5676100

Remittance Options:

Via Mail:

PFM Group Consulting LLC
PO Box 65126
Baltimore, MD 21264-5126
United States of America

RE: January 2023 Postage \$2.28

Expenses	\$2.28
Total Amount Due	\$2.28



INVOICE

Page: 1

Please Remit Payment to:

Solitude Lake Management, LLC
 1320 Brookwood Drive
 Suite H
 Little Rock, AR 72202
 Phone #: (888) 480-5253
 Fax #: (888) 358-0088

Invoice Number: PSI-31624
 Invoice Date: 12/8/2022

Bill
 To: Lakeside Preserve CDD
 PFM Group Consulting
 12051 Corporate Blvd
 Orlando, FL 32817

Ship
 To: Lakeside Preserve CDD
 PFM Group Consulting
 12051 Corporate Blvd
 Orlando, FL 32817
 United States

Ship Via
 Ship Date 12/8/2022
 Due Date 1/7/2023
 Terms Net 30

Customer ID 6861
 P.O. Number
 P.O. Date 12/8/2022
 Our Order No.

Item/Description	Unit	Order Qty	Quantity	Unit Price	Total Price
Annual Maintenance December Billing 12/1/2022 - 12/31/2022 Lakeside Preserve Cdd-Lake-All		1	1	847.68	847.68

Amount Subject to Sales Tax 0.00
 Amount Exempt from Sales Tax 847.68

Subtotal: 847.68
 Invoice Discount: 0.00
 Total Sales Tax: 0.00
 Payment Amount: 0.00
Total: 847.68



INVOICE

Page: 1

Please Remit Payment to:

Solitude Lake Management, LLC
 1320 Brookwood Drive
 Suite H
 Little Rock, AR 72202
 Phone #: (888) 480-5253
 Fax #: (888) 358-0088

Invoice Number: PSI-41367
 Invoice Date: 1/5/2023

Bill
 To: Lakeside Preserve CDD
 PFM Group Consulting
 12051 Corporate Blvd
 Orlando, FL 32817

Ship
 To: Lakeside Preserve CDD
 PFM Group Consulting
 12051 Corporate Blvd
 Orlando, FL 32817
 United States

Ship Via
 Ship Date 1/5/2023
 Due Date 2/4/2023
 Terms Net 30

Customer ID 6861
 P.O. Number
 P.O. Date 1/5/2023
 Our Order No.

Item/Description	Unit	Order Qty	Quantity	Unit Price	Total Price
Annual Maintenance January Billing 1/1/2023 - 1/31/2023 Lakeside Preserve Cdd-Lake-All		1	1	847.68	847.68

Amount Subject to Sales Tax 0.00
 Amount Exempt from Sales Tax 847.68

Subtotal: 847.68
 Invoice Discount: 0.00
 Total Sales Tax: 0.00
 Payment Amount: 0.00
Total: 847.68



RECEIVED

By Verona Griffith at 9:09 am, Mar 02, 2023

INVOICE

Page: 1

Please Remit Payment to:

Solitude Lake Management, LLC
 1320 Brookwood Drive
 Suite H
 Little Rock, AR 72202
 Phone #: (888) 480-5253
 Fax #: (888) 358-0088

Invoice Number: PSI-55723
 Invoice Date: 3/1/2023

Bill
 To: Lakeside Preserve CDD
 PFM Group Consulting
 12051 Corporate Blvd
 Orlando, FL 32817

Ship
 To: Lakeside Preserve CDD
 PFM Group Consulting
 12051 Corporate Blvd
 Orlando, FL 32817
 United States

Ship Via
 Ship Date 3/1/2023
 Due Date 3/31/2023
 Terms Net 30

Customer ID 6861
 P.O. Number
 P.O. Date 3/1/2023
 Our Order No.

Item/Description	Unit	Order Qty	Quantity	Unit Price	Total Price
Annual Maintenance March Billing 3/1/2023 - 3/31/2023 Lakeside Preserve Cdd-Lake-All		1	1	847.68	847.68

Amount Subject to Sales Tax 0.00
 Amount Exempt from Sales Tax 847.68

Subtotal: 847.68
 Invoice Discount: 0.00
 Total Sales Tax: 0.00
 Payment Amount: 0.00
Total: 847.68



A E I D E K K R E K H E R K E K O M M U N I T Y D E V E L O P M E N T D I S T R I C T
 4000 K K I N K R E E K K R I D K E N T R K
 LA K E L A N D K F L 3 3 8 0 2 K U S K
A u K K 3591280K

ag 4 K of 2

03/30/2023	\$18.71
-------------------	----------------

Bill Summary K



1 kWh @ 0.05015 K \$267

For a more detailed explanation of rates and charges please see reverse side.

Bill Date: 03/02/2023

Previous Bill K	\$20.13
Payments/Credits>Returns since 02/01/2023 K	\$-20.39
Balance Forward K	\$-0.26
Electric Service Charges K	\$18.97
Total Current Charges K	\$18.97
Total Amount Due by 03/30/2023 K	\$18.71

Billing details located on following page(s).

Contact Us K

- Electric / Water Billing Inquiries .K..... 863-834-9535
- Wastewater / Solid Waste Billing .K..... 863-834-8276
- Fallen Power Lines / Water Outages .K..... 863-834-4248
- False Alarms (Lakeland Police Dept) 863-834-6940
- Miscellaneous File Dept Billings..... 863-834-8201
- 24-Hour Power Outage Reporting .K..... 866-834-4248
- 24-Hour Payment Hotline 863-834-9535
- TDD (For Hearing Impaired)..... 863-834-8333
- Recycling .K..... 863-834-8774
- Surge Protection .K..... 863-834-1500

Message Center

Online: lakelandelectric.com K

Mail: P.O. Box 32006 Lakeland, FL 33802-2006 K

Phone: (863) 834-9535 K

08

Please return this stub along with your payment and note the account number on your check or money order to ensure proper credit to your account.



A K u K K
3591280

Due Date K	Amount Due K
03/30/2023 K	\$18.71

\$

K									
---	--	--	--	--	--	--	--	--	--

 , US Dollar Amount Enclosed K

LA K E S I E R V I C E C O M M U N I T Y D E V E L O P M E N T D I S T R I C T
 12051 C O R O R A T E K B L K
 O R L A N D K F L 3 2 8 1 7

VISIT OUR EZPAY KIOSKS
Payments will post to your account immediately.

Scan this QR code at our
EZPAY kiosks
to go directly to your account.

Please see back of stub for Kiosk locations. K

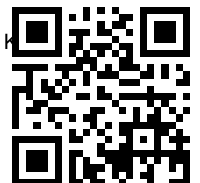

Account # **359128**

Electric Service

Meter Number	No. of Days	Unit of Measure	Current Month	Previous Month	Last Year
3225560	29	kWh	51 0	54 0	68 0

Meter Reading Dates: 01/31/2023 to 03/01/2023

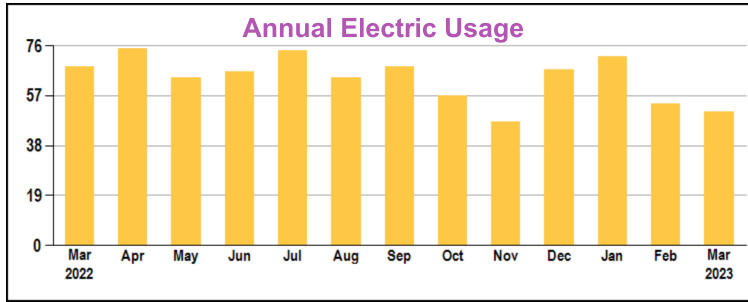

General service Customer Charge	\$13.00
Electric 51 WH @ 0.05015	\$2.57
Environmental Charge 51 WH @ 0.0024097 0	\$0.12
Fuel Charge 51 WH @ 0.055 0	\$2.81
Florida Gross Receipts Tax	\$0.47

Current Electric Service Charges \$18.97 0

If balances are subject to penalty if paid after the due date, please see summary of all charges on Page 1 of your bill. 0

Running a business isn't easy, but choosing the right price plan can be. It only takes minutes with our price plan comparison tool.

TRY IT NOW AT

LAKELANDELECTRIC.COM/ENERGYTOOLSET



The City of Lakeland collects social security numbers for the following purposes: account classification; customer identification; verification; billing; payment; creditworthiness; and any lawful purposes in the conduct of City of Lakeland business.

Address Change

There are several ways to change your mailing address! 0

- Visit lakelandelectric.com/MyAccount
- Email us at customerservice@lakelandelectric.com
- Call us at 863-834-9535

Our call center hours are, Monday - Friday from 7:30 a.m. to 6:00 p.m.

EZPay Kiosk Locations

Drive-Through Kiosk
 Lakeland Electric - 501 Lemon Street

Walk-Up Kiosk
 Harry R Jackson Library - 1700 N. Florida Ave.
 Kelly Recreation Center - 404 Imperial Blvd.
 Town Center - 989 Memorial Blvd.

All payments made at the kiosk post to your account in real-time! 0

Account # **3591279**

Electric Service

Meter Number	No. of Days	Unit of Measure	Current Month	Previous Month	Last Year
05740	29	kWh	263.4	314	363

Meter Reading Dates: 01/31/2023 to 03/01/2023

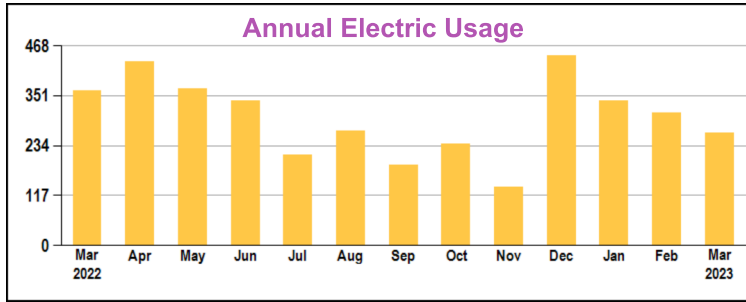

General Service Charge	\$13.00
Electric 263 WH @ 0.05015	\$13.18
Environmental Charge 263 WH @ 0.0024974	\$0.63
Fuel Charge 263 WH @ 0.055	\$14.66
Florida Gross Receipts Tax	\$1.06
Florida Regulatory Commission surcharge	\$0.01

Current Electric Service Charges \$42.34

All balances are subject to penalty if paid after the due date, please see summary of all charges on Page 1 of your bill.

Running a business isn't easy, but choosing the right price plan can be. It only takes minutes with our price plan comparison tool.

TRY IT NOW AT

LAKELANDELECTRIC.COM/ENERGYTOOLSET



The City of Lakeland collects social security numbers for the following purposes: account classification; customer identification; verification; billing; payment; creditworthiness; and any lawful purposes in the conduct of City of Lakeland business.

Address Change

There are several ways to change your mailing address!

- Visit lakelandelectric.com/MyAccount
- Email us at customerservice@lakelandelectric.com
- Call us at 863-834-9535

Our call center hours are, Monday - Friday from 7:30 a.m. to 6:00 p.m.

EZPay Kiosk Locations

Drive-Through Kiosk

Lakeland Electric - 501 Lemon Street

Walk-Up Kiosk

Harry R Jackson Library - 1700 N. Florida Ave.
Kelly Recreation Center - 0 Imperial Blvd.
Town Center - 989 Memorial Blvd.

All payments made at the kiosk post to your account in real-time!

**Lakeside Preserve
COMMUNITY DEVELOPMENT DISTRICT**

Payment Authorization No. 165

4/13/2023

Item No.	Vendor	Invoice Number	FY23 General Fund
1	Prince & Sons Inc Landscape Maintenance April 2023	8483	\$ 4,265.00
2	Lakeland Electric Utility	3591280	\$ 23.39
	Utility	3591279	\$ 51.47
3	Solitude Lake Management Annual Maintenance April 2023	PSI-61513	\$ 847.68
			\$ 5,187.54
TOTAL			\$ 5,187.54

District Manager/

Board Member

Please Return To:
Lakeside Preserve CDD
c/o PFM Group Consulting
3501 Quadrangle Blvd, Suite 270
Orlando, FL 32817



A E I D E K K R E K H E R N E K K O M M U N I T Y D E V E L O P M E N T D I S T R I C T
 4000 K K I N K R E E K K R D K K E N T R K
 LA K E L A N D K F L 3 2 8 1 7 K U S K
 A u K K 3591280K

agK of 2

05/01/2023	\$23.39
------------	---------

Bill Summary K



84 kWh @ 0.05083 K \$4.27

Bill Date: 04/03/2023

For a more detailed explanation of rates and charges, please see the reverse side.

Previous Bill K	\$18.71
Payments/Credits>Returns since 03/02/2023 K	\$-19.00
Balance Forward K	\$-0.29
Electric Service Charges K	\$23.68
Taxal Current Charges K	\$23.68
Total Amount Due by 05/01/2023 K	\$23.39

Bill details located on following page(s).

PAY YOUR LAKELAND ELECTRIC UTILITY BILL WITH CASH AT PARTICIPATING STORES

powered by KUBRA EZ-PAY

Bring this barcode with you to make a payment.
Payments are recognized immediately and posted next business day.

Retailer Instructions:

1. **SCAN** the customer's barcode.
2. The register will **PROMPT** you to enter an amount.
3. **ENTER** the amount the customer wants to pay.
4. **COLLECT** the desired cash amount (and fee, if applicable).
5. When the transaction is **COMPLETE** hand customer the receipt.

7993664236000037168359781280 K

By accepting or using this barcode to make a payment, you agree to the full terms and conditions available at vanilladirect.com/pay/terms. After successful payment using this barcode, you may retrieve your full detailed e-receipt at vanilladirect.com/pay/ereceipt.

Message Center K

08 K
 Please return this stub along with your payment and note the account number on your check or money order to ensure proper credit to your account.



A K u K
 3591280 K

Date K	Amount Due K
05/01/2023 K	\$23.39

\$

K									
---	--	--	--	--	--	--	--	--	--

,

K					
---	--	--	--	--	--

.
 US Dollar Amount Enclosed K

LA K E S I E K R E S E R V E K O M M U N I T Y D E V E L O P M E N T D I S T R I C T
 12051 C O R O R A T E K B L K
 O R L A N D K F L 3 2 8 1 7



Account # **359128 0**

Bill Detail

Electric Service

Meter Number	No. of Days	Unit of Measure	Current Month	Previous Month	Last Year
322556	32	kWh	84	510	75 0

Meter Reading Dates: 03/01/2023 to 04/02/2023

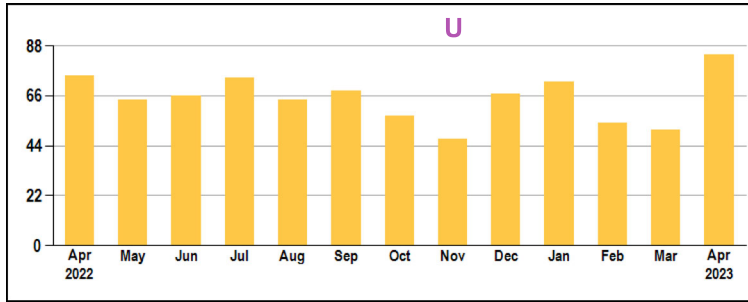

General Service Customer Charge	\$14.00
Electric 84 WH @ 0.05083	\$4.27
Environmental Charge 84 WH @ 0.002409700	\$0.20
Fuel Charge 84 WH @ 0.055	\$4.62
Florida Gross Receipts Tax	\$0.59 0

Current Electric Service Charges 0 \$23.68 0

All balances are subject to penalty if paid after the due date, please see summary of all charges on Page 1 of your bill.

Running a business isn't easy, but choosing the right price plan can be. It only takes minutes with our price plan comparison tool.

TRY IT NOW AT

LAKELANDELECTRIC.COM/ENERGYTOOLSET



The City of Lakeland collects social security numbers for the following purposes: account classification; customer identification; verification; billing; payment; creditworthiness; and any lawful purposes in the conduct of City of Lakeland business.

Address Change

There are several ways to change your mailing address! 0

- Visit lakelandelectric.com/MyAccount
- Email us at customerservice@lakelandelectric.com
- Call us at 863-834-9535

Our call center hours are, Monday - Friday from 7:30 a.m. to 6:00 p.m.

Contact

- Electric / Water Billing Inquiries..... 863-834-9535
- Wastewater / Solid Waste Billing..... 863-834-8276
- Fallen Power Lines / Water Outages..... 863-834-4248
- False Alarms (Lakeland Police Dept)..... 863-834-6936
- Miscellaneous Fire Dept Billings..... 863-834-8201 0
- 24-Hour Power Outage Reporting..... 866-834-4248
- 24-Hour Payment Hotline..... 863-834-9535
- TDD (For Hearing Impaired)..... 863-834-8333
- Recycling..... 863-834-8774
- Storm Surge Protection..... 863-834-1500 0



L K SID R S R COMMUNI Y D L O P N DIS RIC
 4115 L K SID R S R BL # WELL
 L KEL ND FL 33811 US
A u t 3591279

Due Date	Amount Due
05/01/2023	\$51.47

Bill Summary A



337 kWh @ 0.05083 \$17.12

For a more detailed explanation of rates and charges, please see reverse side.

Billi g Date: 04/03/2023

revious Bill \$42.08
 ayments/Credits/Returns since 03/02/2023 A \$-42.37

Bala e F rward \$-0.29

Electric Service Charges \$51.76

T tal Curre t Charges \$51.76 A

T tal Amou t Due by 05/01/2023 \$51.47 A

Billing details located on following page(s) ▶

PAY YOUR LAKELAND ELECTRIC UTILITY BILL WITH CASH AT PARTICIPATING STORES	powered by KUBRAEZ-PAY
<p>Bring this barcode with you to make a payment. <small>Payments are recognized immediately and posted next business day.</small></p> <p>Retailer Instructions:</p> <ol style="list-style-type: none"> SCAN the customer's barcode. The register will PROMPT you to enter an amount. ENTER the amount the customer wants to pay. COLLECT the desired cash amount (and fee, if applicable). When the transaction is COMPLETE hand customer the receipt. <p>799366423610006371683597912600 A</p> <p><small>By accepting or using this barcode to make a payment, you agree to the full terms and conditions available at vanilladirect.com/pay/terms. After successful payment using this barcode, you may retrieve your full detailed e-receipt at vanilladirect.com/pay/ereceipt.</small></p>	 <small>Available at Service Desk or Money Center</small>

Message Ce ter A

08

Please return this stub along with your payment and note the account number on your check or money order to ensure proper credit to your account.



A u t 3591279 A

Due Date	Amount Due
05/01/2023 A	\$51.47 A

\$

A							
---	--	--	--	--	--	--	--

 ,

A		
---	--	--

 .

A

 USD Amount Enclosed

L KESIDE RESERVE COMMUNITY DEVELOPMENT DISTRICT
 12051 COR OR TE BLVD
 ORL NDO FL 32817

Account # **3591279**

Electric Service

Meter Number	No. of Days	Unit of Measure	Current Month	Previous Month	Last Year
05740	3244	kWh	3374	26344	314

Meter Reading Dates: 03/01/2023 to 02/20/23

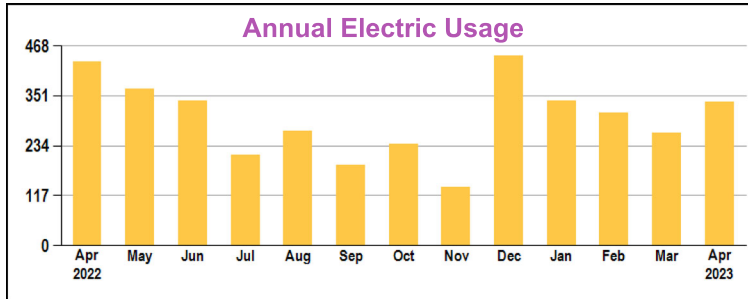

General Service Customer Charge	\$1.00
Electric 337 WH @ 0.05083	\$17.12
Environmental Charge 337 WH @ 0.0020974	\$0.81
Fuel Charge 337 WH @ 0.055	\$18.53
Florida Gross Receipts Tax	\$1.29
Florida Regulatory Commission surcharge	\$0.01

Current Electric Service Charges **\$51.76**

All balances are subject to penalty if paid after the due date, please see summary of all charges on Page 1 of your bill.

Running a business isn't easy, but choosing the right price plan can be. It only takes minutes with our price plan comparison tool.

TRY IT NOW AT

LAKELANDELECTRIC.COM/ENERGYTOOLSET



The City of Lakeland collects social security numbers for the following purposes: account classification; customer identification; verification; billing; payment; creditworthiness; and any lawful purposes in the conduct of City of Lakeland business.

Address Change

There are several ways to change your mailing address!

- Visit lakelandelectric.com/MyAccount
- Email us at customerservice@lakelandelectric.com
- Call us at 863-834-9535

Our call center hours are, Monday - Friday from 7:30 a.m. to 6:00 p.m.

Contact

- Electric / Water Billing Inquiries..... 863-83 -9535
- Wastewater / Solid Waste Billing..... 863-83 -8276
- Fallen Power Lines / Water Outages..... 863-83 - 2 8
- False Alarms (Lakeland Police Dept)..... 863-83 -6936
- Miscellaneous Fire Dept Billings..... 863-83 -8201
- 2 -Hour Power Outage Reporting..... 866-83 - 2 8
- 2 -Hour Payment Hotline..... 863-83 -9535
- TDD (For Hearing Impaired)..... 863-83 -8333
- Recycling..... 863-83 -877
- Surge Protection..... 863-83 -1500

PRINCE & SONS, INC.
 200 South F Street
 Haines City, FL 33844



Invoice

DATE	INVOICE NO.
4/1/2023	8483

BILL TO
Lakeside Preserve-Lakeland Lakeside Preserve CDD c/o PFM Group Consulting, LLC 12051 Corporate Blvd. Orlando, Florida 32817

PLACE OF SERVICE
Lakeside Preserve-Lakeland 4006 Shearwater Street Lakeland, Florida 33811

RECEIVED
 By Verona Griffith at 9:35 am, Apr 07, 2023

TERMS	DUE DATE	P&S WO#	Rep	Vendor PO #
Net 30	5/1/2023			

DESCRIPTION	Quantity	RATE	AMOUNT
April Landscape Maintenance	1	3,675.00	3,675.00
Horticulture	1	350.00	350.00
Irrigation Inspection	1	240.00	240.00

Phone #	E-mail Accounts@princeandsonsinc.com	Total	\$4,265.00
		Payments/Credits	\$0.00
8634225207	Web Site www.Princeandsonsinc.com	Balance Due	\$4,265.00



RECEIVED

By Verona Griffith at 9:39 am, Apr 03, 2023

INVOICE

Page: 1

Please Remit Payment to:

Solitude Lake Management, LLC
 1320 Brookwood Drive
 Suite H
 Little Rock, AR 72202
 Phone #: (888) 480-5253
 Fax #: (888) 358-0088

Invoice Number: PSI-61513
 Invoice Date: 4/1/2023

Bill
 To: Lakeside Preserve CDD
 PFM Group Consulting
 12051 Corporate Blvd
 Orlando, FL 32817

Ship
 To: Lakeside Preserve CDD
 PFM Group Consulting
 12051 Corporate Blvd
 Orlando, FL 32817
 United States

Ship Via
 Ship Date 4/1/2023
 Due Date 5/1/2023
 Terms Net 30

Customer ID 6861
 P.O. Number
 P.O. Date 4/1/2023
 Our Order No.

Item/Description	Unit	Order Qty	Quantity	Unit Price	Total Price
Annual Maintenance April Billing 4/1/2023 - 4/30/2023 Lakeside Preserve Cdd-Lake-All		1	1	847.68	847.68

Amount Subject to Sales Tax 0.00
 Amount Exempt from Sales Tax 847.68

Subtotal: 847.68
 Invoice Discount: 0.00
 Total Sales Tax: 0.00
 Payment Amount: 0.00
Total: 847.68



A E I D E K K R E K H E R V E K K O M M U N I T Y D E V E L O P M E N T D I S T R I C T
 4000 K K I N K R E E K K R D K K E N T R K
 LA K E L A N D K F L 3 2 8 1 7 K U S K
 A u K K 3591280K

ag 4 K of 2

05/01/2023	\$23.39
-------------------	----------------

Bill Summary K



84 kWh @ 0.05083 K \$4.27

Bill Date: 04/03/2023

For a more detailed explanation of rates and charges, please see the reverse side.

Previous Bill K	\$18.71
Payments/Credits>Returns since 03/02/2023 K	\$-19.00
Balance Forward K	\$-0.29
Electric Service Charges K	\$23.68
Tax/Curtailment Charges K	\$23.68
Total Amount Due by 05/01/2023 K	\$23.39

Bill details located on following page(s).

PAY YOUR LAKELAND ELECTRIC UTILITY BILL WITH CASH AT PARTICIPATING STORES

powered by KUBRA EZ-PAY

Bring this barcode with you to make a payment.
Payments are recognized immediately and posted next business day.

Retailer Instructions:

1. **SCAN** the customer's barcode.
2. The register will **PROMPT** you to enter an amount.
3. **ENTER** the amount the customer wants to pay.
4. **COLLECT** the desired cash amount (and fee, if applicable).
5. When the transaction is **COMPLETE** hand customer the receipt.



7993664236000037168359781280 K

By accepting or using this barcode to make a payment, you agree to the full terms and conditions available at vanilladirect.com/pay/terms. After successful payment using this barcode, you may retrieve your full detailed e-receipt at vanilladirect.com/pay/ereceipt.



Message Center K

08 K
 Please return this stub along with your payment and note the account number on your check or money order to ensure proper credit to your account.



A K u K
 3591280 K

Date K	Amount Due K
05/01/2023 K	\$23.39

\$

--	--	--	--	--	--	--	--

 , K

--	--	--	--

 .

--	--

 US Dollar Amount Enclosed K

LA K E S I E K R E S E R V E K O M M U N I T Y D E V E L O P M E N T D I S T R I C T
 12051 C O R O R A T E K B L K
 O R L A N D K F L 3 2 8 1 7



Account # **359128 0**

Bill Detail

Electric Service

Meter Number	No. of Days	Unit of Measure	Current Month	Previous Month	Last Year
322556	32	kWh	84	510	75 0

Meter Reading Dates: 03/01/2023 to 04/02/2023

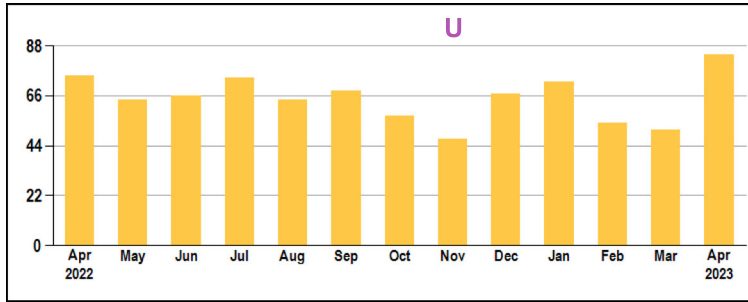

General Service Customer Charge	\$14.00
Electric 84 WH @ 0.05083	\$4.27
Environmental Charge 84 WH @ 0.002409700	\$0.20
Fuel Charge 84 WH @ 0.055	\$4.62
Florida Gross Receipts Tax	\$0.59 0

Current Electric Service Charges 0 \$23.68 0

All balances are subject to penalty if paid after the due date, please see summary of all charges on Page 1 of your bill.

Running a business isn't easy, but choosing the right price plan can be. It only takes minutes with our price plan comparison tool.

TRY IT NOW AT

LAKELANDELECTRIC.COM/ENERGYTOOLSET



The City of Lakeland collects social security numbers for the following purposes: account classification; customer identification; verification; billing; payment; creditworthiness; and any lawful purposes in the conduct of City of Lakeland business.

Address Change

There are several ways to change your mailing address! 0

- Visit lakelandelectric.com/MyAccount
- Email us at customerservice@lakelandelectric.com
- Call us at 863-834-9535

Our call center hours are, Monday - Friday from 7:30 a.m. to 6:00 p.m.

Contact

- Electric / Water Billing Inquiries..... 863-834-9535
- Wastewater / Solid Waste Billing..... 863-834-8276
- Fallen Power Lines / Water Outages..... 863-834-4248
- False Alarms (Lakeland Police Dept)..... 863-834-6936
- Miscellaneous Fire Dept Billings..... 863-834-8201 0
- 24-Hour Power Outage Reporting..... 866-834-4248
- 24-Hour Payment Hotline..... 863-834-9535
- TDD (For Hearing Impaired)..... 863-834-8333
- Recycling..... 863-834-8774
- Storm Surge Protection..... 863-834-1500 0

Account # **3591279**

Electric Service

Meter Number	No. of Days	Unit of Measure	Current Month	Previous Month	Last Year
05740	3244	kWh	3374	26344	314

Meter Reading Dates: 03/01/2023 to 02/20/23

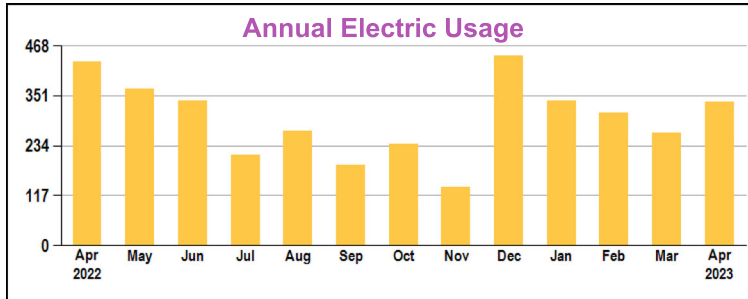

General Service Customer Charge	\$1.00
Electric 337 WH @ 0.05083	\$17.12
Environmental Charge 337 WH @ 0.0020974	\$0.81
Fuel Charge 337 WH @ 0.055	\$18.53
Florida Gross Receipts Tax	\$1.29
Florida Regulatory Commission surcharge	\$0.01

Current Electric Service Charges **\$51.76**

All balances are subject to penalty if paid after the due date, please see summary of all charges on Page 1 of your bill.

Running a business isn't easy, but choosing the right price plan can be. It only takes minutes with our price plan comparison tool.

TRY IT NOW AT

LAKELANDELECTRIC.COM/ENERGYTOOLSET



The City of Lakeland collects social security numbers for the following purposes: account classification; customer identification; verification; billing; payment; creditworthiness; and any lawful purposes in the conduct of City of Lakeland business.

Address Change

There are several ways to change your mailing address!

- Visit lakelandelectric.com/MyAccount
- Email us at customerservice@lakelandelectric.com
- Call us at 863-834-9535

Our call center hours are, Monday - Friday from 7:30 a.m. to 6:00 p.m.

Contact

- Electric / Water Billing Inquiries..... 863-83 -9535
- Wastewater / Solid Waste Billing..... 863-83 -8276
- Fallen Power Lines / Water Outages..... 863-83 - 2 8
- False Alarms (Lakeland Police Dept)..... 863-83 -6936
- Miscellaneous Fire Dept Billings..... 863-83 -8201
- 2 -Hour Power Outage Reporting..... 866-83 - 2 8
- 2 -Hour Payment Hotline..... 863-83 -9535
- TDD (For Hearing Impaired)..... 863-83 -8333
- Recycling..... 863-83 -877
- Emergency Protection..... 863-83 -1500

PRINCE & SONS, INC.
 200 South F Street
 Haines City, FL 33844



Invoice

DATE	INVOICE NO.
4/1/2023	8483

BILL TO
Lakeside Preserve-Lakeland Lakeside Preserve CDD c/o PFM Group Consulting, LLC 12051 Corporate Blvd. Orlando, Florida 32817

PLACE OF SERVICE
Lakeside Preserve-Lakeland 4006 Shearwater Street Lakeland, Florida 33811

RECEIVED
 By Verona Griffith at 9:35 am, Apr 07, 2023

TERMS	DUE DATE	P&S WO#	Rep	Vendor PO #
Net 30	5/1/2023			

DESCRIPTION	Quantity	RATE	AMOUNT
April Landscape Maintenance	1	3,675.00	3,675.00
Horticulture	1	350.00	350.00
Irrigation Inspection	1	240.00	240.00

Phone #	E-mail Accounts@princeandsonsinc.com	Total	\$4,265.00
		Payments/Credits	\$0.00
8634225207	Web Site www.Princeandsonsinc.com	Balance Due	\$4,265.00



RECEIVED

By Verona Griffith at 9:39 am, Apr 03, 2023

INVOICE

Page: 1

Please Remit Payment to:

Solitude Lake Management, LLC
1320 Brookwood Drive
Suite H
Little Rock, AR 72202
Phone #: (888) 480-5253
Fax #: (888) 358-0088

Invoice Number: PSI-61513
Invoice Date: 4/1/2023

Bill

To: Lakeside Preserve CDD
PFM Group Consulting
12051 Corporate Blvd
Orlando, FL 32817

Ship

To: Lakeside Preserve CDD
PFM Group Consulting
12051 Corporate Blvd
Orlando, FL 32817
United States

Ship Via
Ship Date 4/1/2023
Due Date 5/1/2023
Terms Net 30

Customer ID 6861
P.O. Number
P.O. Date 4/1/2023
Our Order No.

Item/Description	Unit	Order Qty	Quantity	Unit Price	Total Price
Annual Maintenance April Billing 4/1/2023 - 4/30/2023 Lakeside Preserve Cdd-Lake-All		1	1	847.68	847.68

Amount Subject to Sales Tax 0.00
Amount Exempt from Sales Tax 847.68

Subtotal: 847.68
Invoice Discount: 0.00
Total Sales Tax: 0.00
Payment Amount: 0.00
Total: 847.68

Lakeside Preserve
COMMUNITY DEVELOPMENT DISTRICT

Payment Authorization No. 167

5/9/2023

Item No.	Vendor	Invoice Number	FY23 General Fund
1	Grau and Associates Audit FY 2022	24073	\$ 2,000.00
2	Prince & Sons Inc Landscape Maintenance May 2023	8791	\$ 4,265.00
3	Lakeland Electric Utility	3591280	\$ 23.09
	Utility	3591279	\$ 57.30
4	Smart Solution Systems Labor and Materials	23089	\$ 300.00
5	Solitude Lake Management Annual Maintenance May 2023	PSI-70045	\$ 847.68
			\$ 7,493.07
TOTAL			\$ 7,493.07

District Manager/ ADM

Board Member

Please Return To:
Lakeside Preserve CDD
c/o PFM Group Consulting
3501 Quadrangle Blvd, Suite 270
Orlando, FL 32817

Grau and Associates

951 W. Yamato Road, Suite 280
Boca Raton, FL 33431-
www.graucpa.com

Phone: 561-994-9299

Fax: 561-994-5823

Lakeside Preserve Community Development District
3501 Quadrangle Boulevard, Suite 270
Orlando, FL 32817

Invoice No. 24073
Date 05/02/2023

RECEIVED

By Verona Griffith at 10:49 am, May 02, 2023

SERVICE	AMOUNT
Audit FYE 09/30/2022	\$ <u>2,000.00</u>
Current Amount Due	\$ <u><u>2,000.00</u></u>

0 - 30	31 - 60	61 - 90	91 - 120	Over 120	Balance
2,000.00	0.00	0.00	0.00	0.00	2,000.00

Payment due upon receipt.

PRINCE & SONS, INC.
 200 South F Street
 Haines City, FL 33844



Invoice

DATE	INVOICE NO.
5/1/2023	8791

BILL TO
Lakeside Preserve-Lakeland Lakeside Preserve CDD c/o PFM Group Consulting, LLC 12051 Corporate Blvd. Orlando, Florida 32817

PLACE OF SERVICE
Lakeside Preserve-Lakeland 4006 Shearwater Street Lakeland, Florida 33811

RECEIVED
 By Verona Griffith at 8:54 am, May 05, 2023

TERMS	DUE DATE	P&S WO#	Rep	Vendor PO #
Net 30	5/31/2023			

DESCRIPTION	Quantity	RATE	AMOUNT
May Landscape Maintenance	1	3,675.00	3,675.00
Horticulture	1	350.00	350.00
Irrigation Inspection	1	240.00	240.00

Phone #	E-mail Accounts@princeandsonsinc.com	Total	\$4,265.00
		Payments/Credits	\$0.00
8634225207	Web Site www.Princeandsonsinc.com	Balance Due	\$4,265.00



L K S D R S R V C MMU TY D V L M T D STR CT
4000 K N CR K RD # NTR
LAK LAND FL 33811 US
A u t 3591280

Due Date	Amou t Due
05/30/2023	\$23.09

Bi | Summary E



81 kWh @ 0.0508E \$4.12

For a more detailed explanation of rates and charges, please see reverse side.

Billi g Date: 05/02/2023

revious Bill	\$23.39
ayments/Credits/REturns since 04/03/2023 E	\$-23.65
Bala e F rward	\$-0.26
lectric Service Charges	\$23.35
T tal Curre t Charges	\$23.35 E
T tal Amou t Due by 05/30/2023	\$23.09 E

Billing details located on following page(s) ▶

PAY YOUR LAKELAND ELECTRIC UTILITY BILL WITH CASH AT PARTICIPATING STORES

powered by KUBRAEZ-PAY

Bring this barcode with you to make a payment.
Payments are recognized immediately and posted next business day.

Retailer Instructions:

- SCAN** the customer's barcode.
- The register will **PROMPT** you to enter an amount.
- ENTER** the amount the customer wants to pay.
- COLLECT** the desired cash amount (and fee, if applicable).
- When the transaction is **COMPLETE** hand customer the receipt.



799366423610006371683597912618 E

By accepting or using this barcode to make a payment, you agree to the full terms and conditions available at vanilladirect.com/pay/terms. After successful payment using this barcode, you may retrieve your full detailed e-receipt at vanilladirect.com/pay/ereceipt.



Message Ce ter E

08

Please return this stub along with your payment and note the account number on your check or money order to ensure proper credit to your account.



A u t
3591280 E

Due Date	Amou t Due E
05/30/2023 E	\$23.09

\$

E									
---	--	--	--	--	--	--	--	--	--

USD Amount Enclosed

LAK SID R S R V COMMUNITY D V LO RM NT DISTRICT E
12051 COR ORAT BLVD
ORLANDO FL 32817

Account # **359128 0**

Bill Detail

Electric Service

Meter Number	No. of Days	Unit of Measure	Current Month	Previous Month	Last Year
322556	29	kWh	81 0	84 0	64 0

Meter Reading Dates: 04/02/2023 to 05/01/2023

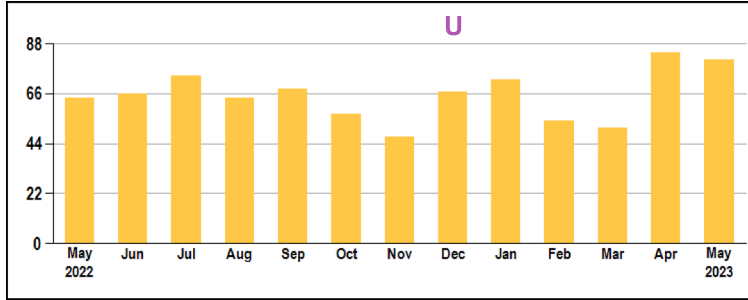

General Service Customer Charge	\$14.00
Electric 81 WH @ 0.05083	\$4.12
Environmental Charge 81 WH @ 0.002409700	\$0.20
Fuel Charge 81 WH @ 0.055	\$4.45
Florida Gross Receipts Tax	\$0.58 0

Current Electric Service Charges 0 \$23.35 0

Bill balances are subject to penalty if paid after the due date, please see summary of all charges on Page 1 of your bill.

Running a business isn't easy, but choosing the right price plan can be. It only takes minutes with our price plan comparison tool.

TRY IT NOW AT

LAKELANDELECTRIC.COM/ENERGYTOOLSET



The City of Lakeland collects social security numbers for the following purposes: account classification; customer identification; verification; billing; payment; creditworthiness; and any lawful purposes in the conduct of City of Lakeland business.

Address Change

There are several ways to change your mailing address! 0

- Visit lakelandelectric.com/MyAccount
- Email us at customerservice@lakelandelectric.com
- Call us at 863-834-9535

Our call center hours are, Monday - Friday from 7:30 a.m. to 6:00 p.m.

Contact

- ⚡💧 Electric / Water Billing Inquiries..... 863-834-9535
- 🗑️💧 Wastewater / Solid Waste Billing..... 863-834-8276
- ⚡🔌 Fallen Power Lines / Water Outages..... 863-834-4248
- 🚓 False Alarms (Lakeland Police Dept)..... 863-834-6936
- 🚒 Miscellaneous Fire Dept Billings..... 863-834-8201 0
- ⚡🔌 24-Hour Power Outage Reporting..... 866-834-4248
- 💰 24-Hour Payment Hotline..... 863-834-9535
- 👤 TDD (For Hearing Impaired)..... 863-834-8333
- ♻️ Recycling..... 863-834-8774
- ⚡🔌 Surge Protection..... 863-834-1500 0



L K S D R S RV C MMU TYD V L M T D STR CT
 4115 L K S D R S RV BL # W LL
 LAK LAND FL 33811 US
A u t 3591279

Due Date	Amou t Due
05/30/2023	\$57.30

Bi l Summary E



389 kWh @ 0.050E3 \$19.77

For a more detailed explanation of rates and charges, please see reverse side.

Billi g Date: 05/02/2023

revious Bill	\$51.47
ayments/Credits/REturns since 04/03/2023 E	\$-51.73 E
Bala e F rward	\$-0.26
lectric Service Charges	\$57.56
T tal Curre t Charges	\$57.56
T tal Amou t Due by 05/30/2023	\$57.30 E

Billing details located on following page(s) ▶

PAY YOUR LAKELAND ELECTRIC UTILITY BILL WITH CASH AT PARTICIPATING STORES

powered by KUBRAEZ-PAY

Bring this barcode with you to make a payment.
Payments are recognized immediately and posted next business day.

Retailer Instructions:

1. **SCAN** the customer's barcode.
2. The register will **PROMPT** you to enter an amount.
3. **ENTER** the amount the customer wants to pay.
4. **COLLECT** the desired cash amount (and fee, if applicable).
5. When the transaction is **COMPLETE** hand customer the receipt.



799366423610006371683597912600 E

By accepting or using this barcode to make a payment, you agree to the full terms and conditions available at vanilladirect.com/pay/terms. After successful payment using this barcode, you may retrieve your full detailed e-receipt at vanilladirect.com/pay/ereceipt.



Message Ce ter E

08

Please return this stub along with your payment and note the account number on your check or money order to ensure proper credit to your account.



A u t 3591279 E

Due Date	Amou t Due E
05/30/2023 E	\$57.30

\$

E					
---	--	--	--	--	--

 ,

E					
---	--	--	--	--	--

 .

--	--	--	--	--	--

USD Amount Enclosed

LAK SID R S RV COMMUNITY D V LO RM NT DISTRICT E
 12051 COR ORAT BLVD
 ORLANDO FL 32817

Account # **3591279**

Electric Service

Meter Number	No. of Days	Unit of Measure	Current Month	Previous Month	Last Year
05740	29	kWh	389	33744	3664

Meter Reading Dates: 0 /02/2023 to 05/01/2023

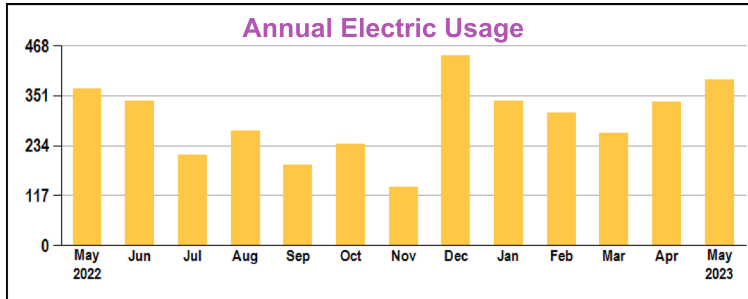

General Service Customer Charge	\$1.00
Electric 389 kWh @ 0.05083	\$19.77
Environmental Charge 389 kWh @ 0.0024974	\$0.9
Fuel Charge 389 kWh @ 0.055	\$21.04
Florida Gross Receipts Tax	\$1.
Florida Regulatory Commission surcharge 4	\$0.01

Current Electric Service Charges \$57.56 4

All balances are subject to penalty if paid after the due date, please see summary of all charges on Page 1 of your bill. 4

Running a business isn't easy, but choosing the right price plan can be. It only takes minutes with our price plan comparison tool.

TRY IT NOW AT

LAKELANDELECTRIC.COM/ENERGYTOOLSET



The City of Lakeland collects social security numbers for the following purposes: account classification; customer identification; verification; billing; payment; creditworthiness; and any lawful purposes in the conduct of City of Lakeland business. 4

Address Change

There are several ways to change your mailing address! 4

- Visit lakelandelectric.com/MyAccount
- Email us at customerservice@lakelandelectric.com
- Call us at 863-834-9535

Our call center hours are, Monday - Friday from 7:30 a.m. to 6:00 p.m.

Contact

- Electric / Water Billing Inquiries..... 863-83 -9535 4
- Wastewater / Solid Waste Billing.4..... 863-83 -8276
- Fallen Power Lines / Water Outages..... 863-83 - 2 8
- False Alarms (Lakeland Police Dept)..... 863-83 -6936
- Miscellaneous Fire Dept Billings..... 863-83 -8201
- 2 -Hour Power Outage Reporting.4..... 866-83 - 2 8
- 2 -Hour Payment Hotline..... 863-83 -9535
- TDD (For Hearing Impaired)..... 863-83 -8333
- Recycling..... 863-83 -877
- Emergency Protection.4..... 863-83 -1500 4

Smart Solution Systems

INVOICE

4309 Norther Dancer Way

Orlando, FL 32826

Phone: 407-676-0131

INVOICE #

23089

DATE

4/28/2023

BILL TO

Lakeside Preserve _Lakeland FL

CUSTOMER ID

Triad

TERMS

Due Upon Receipt

Attn.

c/o TRIAD Association Management, Inc.

711 W Main St

Leesburg, FL 34748

RECEIVED

By Verona Griffith at 9:10 am, May 02, 2023

DESCRIPTION	QTY	UNIT PRICE	AMOUNT
Lakeside Preserve- Lakeland FL			-
			-
Lakeside Preserve large debris clean-up			-
• Remove large logs, loose trash and pallet from debris pile.			-
• Separate palm fronds and branches into separate piles.			-
• Move debris to street side and separate in 3 piles.			-
• Make arrangements with county to pick up debris piles Tuesday 4-25.			-
• Dispose of loose trash and large logs at county landfill.			-
			-
			-
			-
			-
Total including all materials and labor			300.00
Triad Association Management			-
			-
<i>Thank you for your business!</i>		SUBTOTAL	300.00
		TAX RATE	0.000%
		TAX	-
Work Completed	4/21/2023	TOTAL	\$ 300.00

Make checks payable to Smart Solution Systems

If you have any questions about this invoice, please contact

manager@smartsolutionprovider.com



INVOICE

Page: 1

Please Remit Payment to:

Solitude Lake Management, LLC
 1320 Brookwood Drive
 Suite H
 Little Rock, AR 72202
 Phone #: (888) 480-5253
 Fax #: (888) 358-0088

RECEIVED

By Verona Griffith at 9:13 am, May 02, 2023

Invoice Number: PSI-70045
 Invoice Date: 5/1/2023

Bill To: Lakeside Preserve CDD
 PFM Group Consulting
 12051 Corporate Blvd
 Orlando, FL 32817

Ship To: Lakeside Preserve CDD
 PFM Group Consulting
 12051 Corporate Blvd
 Orlando, FL 32817
 United States

Ship Via
 Ship Date 5/1/2023
 Due Date 5/31/2023
 Terms Net 30

Customer ID 6861
 P.O. Number
 P.O. Date 5/1/2023
 Our Order No.

Item/Description	Unit	Order Qty	Quantity	Unit Price	Total Price
Annual Maintenance May Billing 5/1/2023 - 5/31/2023 Lakeside Preserve Cdd-Lake-All		1	1	847.68	847.68

Amount Subject to Sales Tax 0.00
 Amount Exempt from Sales Tax 847.68

Subtotal: 847.68
 Invoice Discount: 0.00
 Total Sales Tax: 0.00
 Payment Amount: 0.00
Total: 847.68

**LAKESIDE PRESERVE
COMMUNITY DEVELOPMENT DISTRICT**

Ratification of Payment Authorization
Nos. 160 – 162, 164 and 166

Lakeside Preserve
COMMUNITY DEVELOPMENT DISTRICT

Payment Authorization No. 160

1/30/2023

Item No.	Vendor	Invoice Number	FY23 General Fund
1	Supervisor Meeting 01/18/2023		
	Dan Lewis	--	\$ 200.00
	Brian Walsh	--	\$ 200.00
	Jeffrey Shenefield	--	\$ 200.00
2	KE Law Group		
	General Counsel	5410	\$ 304.50
3	Prince & Sons Inc		
	Irrigation	7905	\$ 342.66
			<hr/>
			\$ 1,247.16
			<hr/>
TOTAL			\$ 1,247.16

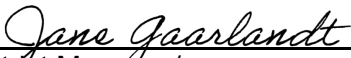
District Manager/

Board Member

Please Return To:
Lakeside Preserve CDD
c/o PFM Group Consulting
3501 Quadrangle Blvd, Suite 270
Orlando, FL 32817

Lakeside Preserve
COMMUNITY DEVELOPMENT DISTRICT

Payment Authorization No. 161
2/4/2023

Item No.	Vendor	Invoice Number	FY23 General Fund
1	Prince & Sons Inc Landscape Maintenance February 2023	8006	\$ 4,265.00
2	Lakeland Electric Utility	3591280	\$ 20.13
	Utility	3591279	\$ 53.76
3	Solitude Lake Management Annual Maintenance	PSI-51316	\$ 847.68
			\$ 5,186.57
TOTAL			\$ 5,186.57

District Manager/

Board Member

Please Return To:
Lakeside Preserve CDD
c/o PFM Group Consulting
3501 Quadrangle Blvd, Suite 270
Orlando, FL 32817

Lakeside Preserve
COMMUNITY DEVELOPMENT DISTRICT

Payment Authorization No. 162
 2/10/2023

Item No.	Vendor	Invoice Number	Fund
1	PFM Group Consulting	DM-02-2023-22	FY23 General

DM Fees - February 2023 \$ 2,291.67

\$ 2,291.67

TOTAL \$ 2,291.67

Jane Gaarandt
 District Manager

Joe Saurin
 Board Member

Please Return To:
 Lakeside Preserve CDD
 c/o PFM Group Consulting
 3501 Quadrangle Blvd, Suite 270
 Orlando, FL 32817

Lakeside Preserve
COMMUNITY DEVELOPMENT DISTRICT

Payment Authorization No. 164

3/28/2023

Item No.	Vendor	Invoice Number	FY23 General Fund
1	Kilinski Van Wyk, PLLC General Counsel	6017	\$ 55.50
2	PFM Group Consulting DM Fees - March 2023	DM-03-2023-22	\$ 2,291.67
3	Prince & Sons Inc Irrigation	8324	\$ 78.09
			\$ 2,425.26
TOTAL			\$ 2,425.26

District Manager/

Board Member

Please Return To:
Lakeside Preserve CDD
c/o PFM Group Consulting
3501 Quadrangle Blvd, Suite 270
Orlando, FL 32817

**Lakeside Preserve
COMMUNITY DEVELOPMENT DISTRICT**

Payment Authorization No. 166

5/1/2023

Item No.	Vendor	Invoice Number	FY23 General Fund
1	CA Florida Holding, LLC Finance Charge	0004924464	\$ 335.30
2	Kilinski Van Wyk, PLLC General Counsel	6405	\$ 341.00
3	PFM Group Consulting DM Fees - April 2023	DM-04-2023-22	\$ 2,291.67
4	Prince & Sons Inc Irrigation	8606	\$ 164.76
			\$ 3,132.73
TOTAL			\$ 3,132.73

District Manager/ ADM

Board Member

Please Return To:
Lakeside Preserve CDD
c/o PFM Group Consulting
3501 Quadrangle Blvd, Suite 270
Orlando, FL 32817

**LAKESIDE PRESERVE
COMMUNITY DEVELOPMENT DISTRICT**

Review of Monthly Financials

Lakeside Preserve CDD
Statement of Financial Position
As of 4/30/2023

	General Fund	Debt Service Fund	Capital Projects Fund	Long-Term Debt Fund	Total
<u>Assets</u>					
<u>Current Assets</u>					
General Checking Account	\$ 174,822.51				\$ 174,822.51
Assessments Receivable	23,975.00				23,975.00
Deposits	305.50				305.50
Due From Other Funds		\$ 999.86			999.86
Series 2019 Debt Service Reserve		90,250.00			90,250.00
Series 2019 Revenue		155,034.68			155,034.68
Series 2019 Interest		31,537.50			31,537.50
Series 2019 Prepayment		4,504.48			4,504.48
Series 2019 Sinking Fund		25,000.00			25,000.00
Series 2019 Acquisition/Construction			\$ 779.36		779.36
Total Current Assets	<u>\$ 199,103.01</u>	<u>\$ 307,326.52</u>	<u>\$ 779.36</u>	<u>\$ -</u>	<u>\$ 507,208.89</u>
<u>Investments</u>					
Amount Available in Debt Service Funds				\$ 306,326.66	\$ 306,326.66
Amount To Be Provided				998,673.34	998,673.34
Total Investments	<u>\$ -</u>	<u>\$ -</u>	<u>\$ -</u>	<u>\$1,305,000.00</u>	<u>\$1,305,000.00</u>
Total Assets	<u><u>\$ 199,103.01</u></u>	<u><u>\$ 307,326.52</u></u>	<u><u>\$ 779.36</u></u>	<u><u>\$1,305,000.00</u></u>	<u><u>\$1,812,208.89</u></u>
<u>Liabilities and Net Assets</u>					
<u>Current Liabilities</u>					
Accounts Payable	\$ 6,447.84				\$ 6,447.84
Deferred Revenue	23,975.00				23,975.00
Total Current Liabilities	<u>\$ 30,422.84</u>	<u>\$ -</u>	<u>\$ -</u>	<u>\$ -</u>	<u>\$ 30,422.84</u>
<u>Long Term Liabilities</u>					
Revenue Bonds Payable - Long-Term				\$1,305,000.00	\$1,305,000.00
Total Long Term Liabilities	<u>\$ -</u>	<u>\$ -</u>	<u>\$ -</u>	<u>\$1,305,000.00</u>	<u>\$1,305,000.00</u>
Total Liabilities	<u><u>\$ 30,422.84</u></u>	<u><u>\$ -</u></u>	<u><u>\$ -</u></u>	<u><u>\$1,305,000.00</u></u>	<u><u>\$1,335,422.84</u></u>
<u>Net Assets</u>					
Net Assets, Unrestricted	\$ (4,500.00)				\$ (4,500.00)
Net Assets - General Government	97,320.60				97,320.60
Current Year Net Assets - General Government	75,859.57				75,859.57
Net Assets, Unrestricted		\$ 239,672.42			239,672.42
Current Year Net Assets, Unrestricted		67,654.10			67,654.10
Net Assets, Unrestricted			\$ 766.23		766.23
Current Year Net Assets, Unrestricted			13.13		13.13
Total Net Assets	<u><u>\$ 168,680.17</u></u>	<u><u>\$ 307,326.52</u></u>	<u><u>\$ 779.36</u></u>	<u><u>\$ -</u></u>	<u><u>\$ 476,786.05</u></u>
Total Liabilities and Net Assets	<u><u>\$ 199,103.01</u></u>	<u><u>\$ 307,326.52</u></u>	<u><u>\$ 779.36</u></u>	<u><u>\$1,305,000.00</u></u>	<u><u>\$1,812,208.89</u></u>

Lakeside Preserve CDD
Statement of Activities
As of 4/30/2023

	General Fund	Debt Service Fund	Capital Projects Fund	Long-Term Debt Fund	Total
<u>Revenues</u>					
On-Roll Assessments	\$ 81,903.12				\$ 81,903.12
Off-Roll Assessments	71,925.00				71,925.00
On-Roll Assessments		\$ 94,831.25			94,831.25
Total Revenues	<u>\$153,828.12</u>	<u>\$ 94,831.25</u>	<u>\$ -</u>	<u>\$ -</u>	<u>\$248,659.37</u>
<u>Expenses</u>					
Supervisor Fees	\$ 600.00				\$ 600.00
Travel and Per Diem	122.78				122.78
D&O Insurance	2,579.60				2,579.60
Trustee Services	2,357.03				2,357.03
Management	13,750.02				13,750.02
Engineering	545.00				545.00
Property Appraiser	5,000.00				5,000.00
District Counsel	2,123.97				2,123.97
Assessment Administration	7,500.00				7,500.00
Reamortization Schedules	125.00				125.00
Postage & Shipping	30.86				30.86
Legal Advertising	1,018.35				1,018.35
Web Site Maintenance	405.00				405.00
Dues, Licenses, and Fees	175.00				175.00
Electric	496.51				496.51
Aquatic Contract	5,933.76				5,933.76
General Insurance	3,076.80				3,076.80
Property & Casualty	1,509.60				1,509.60
Irrigation	777.06				777.06
Landscaping Maintenance & Material	29,855.00				29,855.00
Interest Payments		\$ 31,537.50			31,537.50
Total Expenses	<u>\$ 77,981.34</u>	<u>\$ 31,537.50</u>	<u>\$ -</u>	<u>\$ -</u>	<u>\$109,518.84</u>
<u>Other Revenues (Expenses) & Gains (Losses)</u>					
Interest Income	\$ 12.79				\$ 12.79
Interest Income		\$ 4,360.35			4,360.35
Interest Income			\$ 13.13		13.13
Total Other Revenues (Expenses) & Gains (Losses)	<u>\$ 12.79</u>	<u>\$ 4,360.35</u>	<u>\$ 13.13</u>	<u>\$ -</u>	<u>\$ 4,386.27</u>
Change In Net Assets	\$ 75,859.57	\$ 67,654.10	\$ 13.13	\$ -	\$143,526.80
Net Assets At Beginning Of Year	\$ 92,820.60	\$ 239,672.42	\$ 766.23	\$ -	\$333,259.25
Net Assets At End Of Year	\$168,680.17	\$ 307,326.52	\$ 779.36	\$ -	\$476,786.05

Lakeside Preserve CDD
 Budget to Actual
 For the Month Ending 4/30/2023

	Year To Date			FY 2023 Adopted Budget
	Actual	Budget	Variance	
<u>Revenues</u>				
On-Roll Assessments	\$ 81,903.12	\$ 47,250.00	\$ 34,653.12	\$ 81,000.00
Off-Roll Assessments	71,925.00	55,941.69	15,983.31	95,900.00
Net Revenues	\$ 153,828.12	\$ 103,191.69	\$ 50,636.43	\$ 176,900.00
<u>General & Administrative Expenses</u>				
Supervisor Fees	\$ 600.00	\$ 1,633.31	\$ (1,033.31)	\$ 2,800.00
D&O Insurance	2,579.60	1,677.06	902.54	2,875.00
Trustee Services	2,357.03	3,500.00	(1,142.97)	6,000.00
Management	13,750.02	16,041.69	(2,291.67)	27,500.00
Field Management	-	291.69	(291.69)	500.00
Engineering	545.00	2,916.69	(2,371.69)	5,000.00
Dissemination Agent	-	2,916.69	(2,916.69)	5,000.00
Property Appraiser	5,000.00	2,916.69	2,083.31	5,000.00
District Counsel	2,123.97	9,333.31	(7,209.34)	16,000.00
Assessment Administration	7,500.00	4,375.00	3,125.00	7,500.00
Reamortization Schedules	125.00	583.31	(458.31)	1,000.00
Audit	-	3,208.31	(3,208.31)	5,500.00
Arbitrage Calculation	-	291.69	(291.69)	500.00
Travel and Per Diem	122.78	145.81	(23.03)	250.00
Telephone	-	58.31	(58.31)	100.00
Postage & Shipping	30.86	175.00	(144.14)	300.00
Copies	-	29.19	(29.19)	50.00
Legal Advertising	1,018.35	1,166.69	(148.34)	2,000.00
Miscellaneous	-	554.82	(554.82)	951.25
Meeting Room	-	350.00	(350.00)	600.00
Web Site Maintenance	405.00	1,645.00	(1,240.00)	2,820.00
Dues, Licenses, and Fees	175.00	102.06	72.94	175.00
Electric	496.51	1,166.69	(670.18)	2,000.00
Irrigation	777.06	2,916.69	(2,139.63)	3,450.00
Aquatic Contract	5,933.76	5,833.31	100.45	5,000.00
General Insurance	3,076.80	2,029.30	1,047.50	10,000.00
Property & Casualty	1,509.60	2,012.50	(502.90)	3,478.75
Landscaping Maintenance & Material	29,855.00	33,541.69	(3,686.69)	57,500.00
Landscape Improvements	-	1,166.69	(1,166.69)	2,000.00
Contingency	-	612.50	(612.50)	1,050.00
Total General & Administrative Expenses	\$ 77,981.34	\$ 103,191.69	\$ (25,210.35)	\$ 176,900.00
Total Expenses	\$ 77,981.34	\$ 103,191.69	\$ (25,210.35)	\$ 176,900.00
Income (Loss) from Operations	\$ 75,846.78	\$ -	\$ 75,846.78	\$ -
<u>Other Income (Expense)</u>				
Interest Income	\$ 12.79	\$ -	\$ 12.79	\$ -
Total Other Income (Expense)	\$ 12.79	\$ -	\$ 12.79	\$ -
Net Income (Loss)	\$ 75,859.57	\$ -	\$ 75,859.57	\$ -

**LAKESIDE PRESERVE
COMMUNITY DEVELOPMENT DISTRICT**

Staff Reports

**LAKESIDE PRESERVE
COMMUNITY DEVELOPMENT DISTRICT**

District Counsel

**LAKESIDE PRESERVE
COMMUNITY DEVELOPMENT DISTRICT**

District Engineer

**LAKESIDE PRESERVE
COMMUNITY DEVELOPMENT DISTRICT**

District Manager



Company: PFM Field Services
Contact: Madison McAdams
Phone: 352-602-4803

Email: PFMFieldServices@triadassocmgmt.com
Title: Lakeside Preserve April 2023
Created: Fri, 4/7/2023

(1)



Missing Wire Cap

Created: Fri, 4/7/2023

Work Order # 302 Highland Homes is reviewing

(2)



Pond

Created: Fri, 4/7/2023



Company: PFM Field Services
Contact: Madison McAdams
Phone: 352-602-4803

Email: PFMFieldServices@triadassocmgmt.com
Title: Lakeside Preserve April 2023
Created: Fri, 4/7/2023

(3)



Pond Landscape

Created: Fri, 4/7/2023

Work Order # 624 Recieved quote for low spot fill.
Awaiting board approval.

(4)



Stormwater Damage

Created: Fri, 4/7/2023

Work Order # 490 Engineer has reviewed and offered
maintenance suggestions. Board is still reviewing.



Company: PFM Field Services
Contact: Madison McAdams
Phone: 352-602-4803

Email: PFMFieldServices@triadassocmgmt.com
Title: Lakeside Preserve April 2023
Created: Fri, 4/7/2023

(5)



Pond

Created: Fri, 4/7/2023

(6)



Pond

Created: Fri, 4/7/2023



Company: PFM Field Services
Contact: Madison McAdams
Phone: 352-602-4803

Email: PFMFieldServices@triadassocmgmt.com
Title: Lakeside Preserve April 2023
Created: Fri, 4/7/2023

(7)



Pond Landscape

Created: Fri, 4/7/2023

(8)



Pond

Created: Fri, 4/7/2023

work Order #774

Ponds have been treated and algae growth has slowed. Will continue to monitor. Last treated 4/5/23

(9)



Pond

Created: Fri, 4/7/2023

(10)



Pond

Created: Fri, 4/7/2023

work Order #774

Ponds have been treated and algae growth has slowed. Will continue to monitor. Last treated 4/5/23



Company: PFM Field Services
Contact: Madison McAdams
Phone: 352-602-4803

Email: PFMFieldServices@triadassocmgmt.com
Title: Lakeside Preserve April 2023
Created: Fri, 4/7/2023

(11)



Pond

Created: Fri, 4/7/2023

(12)



Pond

Created: Fri, 4/7/2023

(13)



Tree Replacement

Created: Fri, 4/7/2023

Tree missing along front pond. Would board like a quote for a replacement?

(14)



Leaning Sign

Created: Fri, 4/7/2023

Leaning sign next to storm water pond. Would the board like quotes for straightening?

(15)



Pond

Created: Fri, 4/7/2023

(16)



Fence

Created: Fri, 4/7/2023

Work Order # 740 Received two fence install quotes. Pending board approval.

(17)



Landscape Debris

Created: Fri, 4/7/2023

Recieved quote for debris removal. Pending board review.



Status Selected: Ready for Inspection, Open, Scheduled, Awaiting Quote, Pending, Awaiting BOD approval, Ready for Payment, Inspection Needed

ID	Due Date/ Follow-up	Description	Assigned To / Contact	Estimate
Awaiting BOD approval				
Fencing				
740		Chain Link fence around retention area		
Entered Date: 2/1/2023				\$0.00
	02/01/2023	At last District meeting, board of supervisors would like quotes to install fencing around community neighboring Heritage Baptist to prevent people from swimming in the retention ponds. There is a partial existing chain link fence.		
		Reached out to one of the board members recommended company Williams Fencing in Lakeland. Tentative appointment on the 13th at 4:00pm.		
		Also looking into other vendors in the area for quotes.		
	02/01/2023	Reached out to Randolph Fencing for a quote.		
	02/01/2023	Association Manager Changed From : Martha Ledford - To : Madison McAdams		
	02/02/2023	Randolph fencing will be out on Friday to inspect and provide a quote.		
		Williams fencing will be onsite February 13th to inspect and provide a quote.		
	02/09/2023	Received quote from Randolph fencing. Williams fencing will be onsite Feb. 13th.		
	02/21/2023	Received quote from Williams fencing and forwarded to PFM for review.		
		Similar pricing. Main difference is one is priced for 193 feet (Williams) and 183 feet (Randolph).		
	02/21/2023	Status Change From: Open To: Awaiting BOD approval Reason :Pending Approval.		
				Fencing Count: 0
Landscaping				
624		Low Spot of landscape next to large retention pond		
Entered Date: 12/6/2022				\$0.00
	12/06/2022	Requested proposal for fill of low spot from Prince & Sons.		
	12/23/2022	Madison sending a follow up		
	12/29/2022	Sent another follow up to vendor.		
	01/13/2023	Requested urgent update through James at Prince and Sons.		
	02/01/2023	Emailed and left message with James from Prince and Sons regarding a quote for the pvc drainage at the low spot that the board would like to explore.		
		Per our conversation prior, James informed me that he has someone on his team who is well experienced in that sort of project.		
	02/01/2023	Association Manager Changed From : Martha Ledford - To : Madison McAdams		
	02/02/2023	Prince and Sons will be onsite Monday afternoon to provide a quote for the project.		
	02/09/2023	Prince & Sons has requested to meet with Board to go over options.		
		Jane with PFM contacted board asking if they would be willing to meet the vendor onsite.		
	02/23/2023	Met with Board Member and James Smith to go over the low spot and the request.		
		Per board member, a simple fill is going to be sufficient. Prince and Sons has stated that they will conduct a quote with this information.		
	03/09/2023	Received quote from vendor 03/8/23. Is to be reviewed by the board.		
	03/09/2023	Status Change From: Open To: Awaiting BOD approval Reason :Pending board approval.		



Status Selected: Ready for Inspection, Open, Scheduled, Awaiting Quote, Pending, Awaiting BOD approval, Ready for Payment, Inspection Needed

ID	Due Date/ Follow-up	Description	Assigned To / Contact	Estimate
Landscaping Count:				0
Professional Services				
484		Erosion at Storm Water area	Stormwater Pond- Cypress View/Lakeside Preserve	
Entered Date: 10/19/2022				\$0.00
	10/19/2022	Engineer to review Erosion at retention pond - see 10/19/22 inspection report		
	11/03/2022	Jane Gaarlandt forwarded inspection report from October 19th to engineer Todd Amaden (tca@lesc.com) to inspect.		
	12/06/2022	Has been brought to the boards attention. Awaiting further direction.		
	12/07/2022	Engineer provided the following:		
		Pond 90 the Control structure the concrete that was installed on the slopes adjacent to the CS-90 weir wall are breaking down and causing erosion. Landmark recommends during the dry season to fill in the voids under the concrete or remove the concrete and place rip rap bags with fabric underneath to prevent further erosion.		
		Pond 100 erosion is starting on both sides of the weir wall. This is an area that will need to be watched. If the area erodes further Landmark recommends adding rip rap bags with fabric underneath to help prevent further erosion.		
	12/29/2022	Reached out to PFM to see if the developer plans on handling the repair.		
	01/03/2023	Per PFM, they will be presenting the engineers findings to the board for consideration.		
	01/03/2023	Status Change From: Open To: Awaiting BOD approval Reason :view notes.		
	02/01/2023	Association Manager Changed From : Martha Ledford - To : Madison McAdams		
486		Fountain Proposals	Future Horizons, Inc. Stormwater Pond- Cypress View/Lakeside Preserve	
Entered Date: 10/19/2022				\$0.00
	10/19/2022	Board would like to see Proposals for the stormwater that are solar powered		
	10/19/2022	Email sent to Future Horizons to request a proposal		
	12/07/2022	Requested update from Future Horizons on proposal.		
	12/28/2022	ML sent followup email		
	01/03/2023	Received solar fountain pricing from Absolute Aquatics. Have not received additional quotes at this time.		
	02/01/2023	Association Manager Changed From : Martha Ledford - To : Madison McAdams		
	02/09/2023	Per last board meeting, have requested quotes for nonsolar fountains: -for both filtration & aesthetics -Include the electric costs associated as well.		
		Also asked solitude for recommendations as they maintain the ponds.		
	02/23/2023	Absolute Aquatics is conducting an estimate for a range of different non solar fountain options.		
Professional Services Count:				0
Awaiting BOD approval Count:				0
Inspection Needed				
Board Project				
391		Exposed Pipe	Stormwater Pond- Cypress View/Lakeside Preserve	
Entered Date: 9/23/2022				\$0.00



Status Selected: Ready for Inspection, Open, Scheduled, Awaiting Quote, Pending, Awaiting BOD approval, Ready for Payment, Inspection Needed

ID	Due Date/ Follow-up	Description	Assigned To / Contact	Estimate
	09/23/2022	There is an exposed pipe near the lift station area that needs to be reviewed to determine if it is stormwater related or irrigation related.		
	10/19/2022	Discussed at District Meeting- Highland Homes reviewing		
	12/07/2022	Was not able to locate at last inspection. Will monitor at next inspection.		
	12/29/2022	Status Change From: Open To: Inspection Needed Reason :Was not able to locate at last inspection.		
	01/13/2023	Was not able to locate at last inspection. However, noticed another broken pipe sticking out of the ground. Include photo in my report and asked that it be reviewed.		
	02/01/2023	Association Manager Changed From : Martha Ledford - To : Madison McAdams		
	02/09/2023	Broken pipe was still present at last inspection. Ask that it be reviewed.		
Board Project Count:				0

Landscaping

687		Entrance Monument Planter	Prince and Sons Inc.	
Entered Date: 1/12/2023				\$0.00
	01/12/2023	Noticed at inspection the monument planter was lacking plants. Emailed vendor requesting proposal for the planter to be filled just like the one on the other side.		
	02/01/2023	Status Change From: Open To: Inspection Needed Reason :Per vendor, landscaping items have been taken care of at last service. Will confirm at next inspection.		
	02/01/2023	Association Manager Changed From : Martha Ledford - To : Madison McAdams		
Landscaping Count:				0
Inspection Needed Count:				0

Open

Board Project

392		Exposed Wires- Missing Cap	Stormwater Pond- Cypress View/Lakeside Preserve	
Entered Date: 9/23/2022				\$0.00
	09/23/2022	There is what appears to be an irrigation box that is missing a cap.		
	10/19/2022	Discussed at District Meeting 10/19/22- Highland Homes reviewing		
	12/07/2022	Still open. Highland Homes is reviewing.		
	01/13/2023	Still open. Highland Homes to review.		
	02/01/2023	Association Manager Changed From : Martha Ledford - To : Madison McAdams		
	02/09/2023	Still open, Highland Homes to review.		
Board Project Count:				0

Landscaping

945		Branches along fence line		
Entered Date: 3/21/2023				\$0.00
	03/21/2023	Received report from an owner about a pile of tree limbs and debris that is piled up outside the community on the easement near the end of the community wall by the church that has been there since the hurricane. Contacted Prince and Sons to have it investigated and addressed.		
	03/24/2023	Vendor advised that the branches are not from his crew and will provide a picture next week showing their location.		
	03/28/2023	Requested follow up from vendor on item.		



Status Selected: Ready for Inspection, Open, Scheduled, Awaiting Quote, Pending, Awaiting BOD approval, Ready for Payment, Inspection Needed

ID	Due Date/ Follow-up	Description	Assigned To / Contact	Estimate
----	------------------------	-------------	-----------------------	----------

Landscaping Count: 0

Pond Maintenance

774

Pond Algae Growth

Entered Date: 2/8/2023

\$0.00

02/08/2023 Noticed algae growth has increased since last visit in January. Emailed solitude to have it addressed at their next visit.

02/23/2023 Requested follow up from vendor on the plan to address.

03/02/2023 Left message with Alan Wilson our point of contact as he has not been responsive by email

03/09/2023 Dexter Glasgow is the new contact for Solitude Lake Management. He informed me that the last service took place 03/2/23 (report attached).

Will monitor at next visit to see if more aggressive action is required.

Pond Maintenance Count: 0

Open Count: 0

Lakeside Preserve CDD Count: 0

Estimate Total: \$0.00

**LAKESIDE PRESERVE
COMMUNITY DEVELOPMENT DISTRICT**

Supervisor Requests and Audience Comments